



UE4740-22H0000

SICK
Sensor Intelligence.



Ordering information

Type	Part no.
UE4740-22H0000	1046978

The system plug has to be ordered separately. For details, see "Accessories".

Other models and accessories → www.sick.com/

Product description

The UE4740 EFI gateway connects intelligent SICK safety sensors to the PROFINET PROFINsafe fieldbus. It has two EFI interfaces for connecting up to four SICK safety sensors, which allows the use of expanded sensor functionalities.

The UE4740 EFI gateway makes it possible to exchange a configurable process image between the EFI sensors and the PLC via PROFINET IO PROFINsafe. This EFI gateway is configured using CDS configuration software CDS, which helps provide simple configuration and diagnostics information.

At a glance

- Support of PROFINET IO conformance class A, LLDP, SNMP, MIB II, cyclic I/O communication, acyclic read/write services for the communication via TCI interface, diagnostics alarm, TCP/IP-communication via port 9000
- Support by PROFINsafe V2.00
- Two inputs (EFI interface) to connect intelligent SICK safety sensors
- Easy configuration and advanced diagnostics with the help of the CDS (Configuration & Diagnostic Software)

Your benefits

- Easy integration of intelligent SICK safety sensors into a PROFINET IO PROFINsafe fieldbus
- Simple use of the enhanced functionalities of SICK's intelligent safety sensors allows information to be easily exchanged via PROFINET IO PROFINsafe
- Comprehensive diagnostics provide fast troubleshooting, which reduces downtime



Detailed technical data

Technical specifications

Accessory family	EFI gateways
Communication interface	PROFINET, PROFIsafe
Note	The system plug has to be ordered separately. For details, see "Accessories".
Enclosure rating	IP20 (IEC 60529)
Weight	147 g
Dimensions (W x H x L)	22.5 mm x 96.5 mm x 120.8 mm
Description	PROFINET PROFIsafe
Safety-related parameters	
Category	Category 4 (EN ISO 13849)
Performance level	PL e (EN ISO 13849)
Safety integrity level	SIL3 (IEC 61508)
PFH _D (mean probability of a dangerous failure per hour)	2.84 x 10 ⁻⁹ (EN ISO 13849)

Classifications

eCl@ss 5.0	27242205
eCl@ss 5.1.4	27242605
eCl@ss 6.0	27242605
eCl@ss 6.2	27242605
eCl@ss 7.0	27242605
eCl@ss 8.0	27242605
eCl@ss 8.1	27242605
eCl@ss 9.0	27242605
eCl@ss 10.0	27242605
eCl@ss 11.0	27242605
eCl@ss 12.0	27242605
ETIM 5.0	EC001601
ETIM 6.0	EC001601
ETIM 7.0	EC001601
ETIM 8.0	EC001601
UNSPSC 16.0901	32151705

Dimensional drawing (Dimensions in mm (inch))

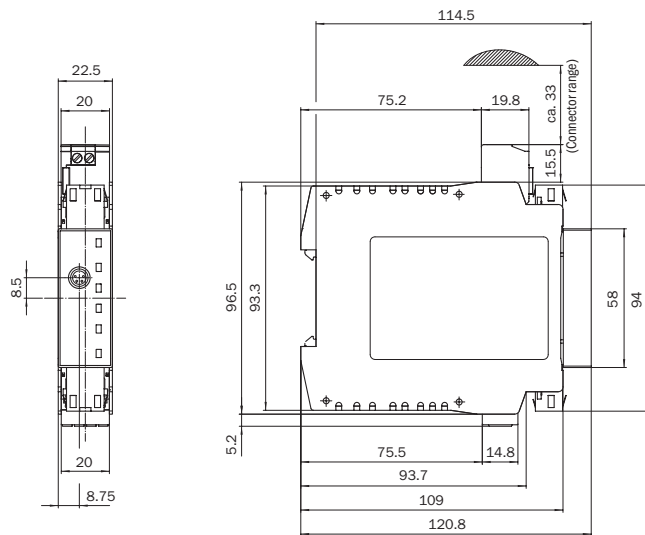

Anschlussschema

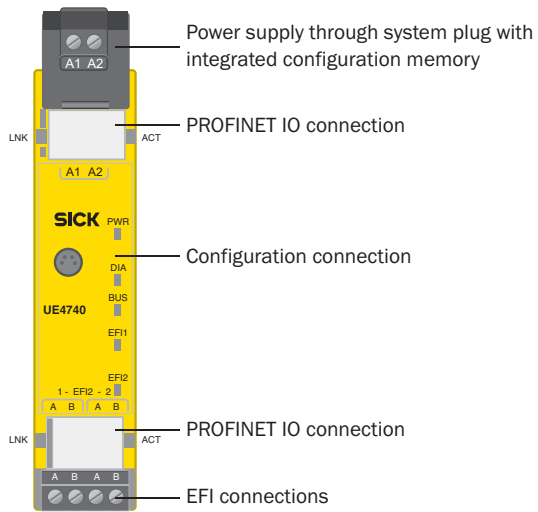

SICK AT A GLANCE

SICK is one of the leading manufacturers of intelligent sensors and sensor solutions for industrial applications. A unique range of products and services creates the perfect basis for controlling processes securely and efficiently, protecting individuals from accidents and preventing damage to the environment.

We have extensive experience in a wide range of industries and understand their processes and requirements. With intelligent sensors, we can deliver exactly what our customers need. In application centers in Europe, Asia and North America, system solutions are tested and optimized in accordance with customer specifications. All this makes us a reliable supplier and development partner.

Comprehensive services complete our offering: SICK LifeTime Services provide support throughout the machine life cycle and ensure safety and productivity.

For us, that is “Sensor Intelligence.”

WORLDWIDE PRESENCE:

Contacts and other locations –www.sick.com