



Indicator lamp

SICK
Sensor Intelligence.



Ordering information

Type	Part no.
Indicator lamp	2033117

The muting indicator lamp is not pre-mounted.

Other models and accessories → www.sick.com/

Detailed technical data

Technical specifications

Accessory group	Muting accessories
Description	Muting lamp
Items supplied	Inclusive male connector M12 and connection cable (10 m), mounting bracket and mounting kit
Indication	Incandescent lamp

Classifications

ECl@ss 5.0	27210301
ECl@ss 5.1.4	27210301
ECl@ss 6.0	27210301
ECl@ss 6.2	27210301
ECl@ss 7.0	27210301
ECl@ss 8.0	27210301
ECl@ss 8.1	27210301
ECl@ss 9.0	27210301
ECl@ss 10.0	27210301
ECl@ss 11.0	27210301
ECl@ss 12.0	27210301
ETIM 5.0	EC001334
ETIM 6.0	EC001334
ETIM 7.0	EC001334
ETIM 8.0	EC001334
UNSPSC 16.0901	32151502

Dimensional drawing (Dimensions in mm (inch))

Muting indicator lamp

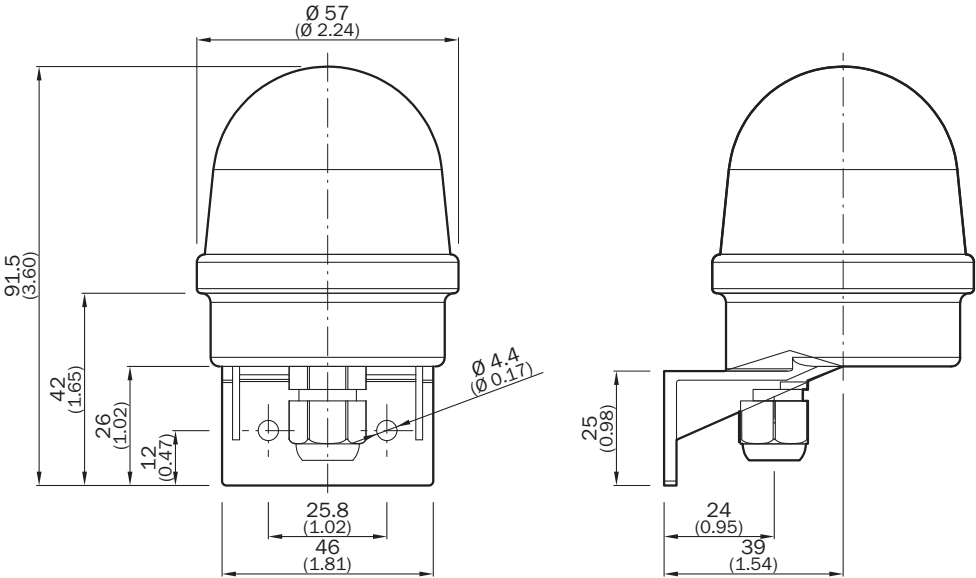

SICK AT A GLANCE

SICK is one of the leading manufacturers of intelligent sensors and sensor solutions for industrial applications. A unique range of products and services creates the perfect basis for controlling processes securely and efficiently, protecting individuals from accidents and preventing damage to the environment.

We have extensive experience in a wide range of industries and understand their processes and requirements. With intelligent sensors, we can deliver exactly what our customers need. In application centers in Europe, Asia and North America, system solutions are tested and optimized in accordance with customer specifications. All this makes us a reliable supplier and development partner.

Comprehensive services complete our offering: SICK LifeTime Services provide support throughout the machine life cycle and ensure safety and productivity.

For us, that is “Sensor Intelligence.”

WORLDWIDE PRESENCE:

Contacts and other locations –www.sick.com