

FX0-GDEV00000

Flexi Soft

SAFETY CONTROLLERS

SICK
Sensor Intelligence.



Ordering information

Fieldbus, industrial network	Type	Part no.
DeviceNet™	FX0-GDEV00000	1044077

Other models and accessories → www.sick.com/Flexi_Soft

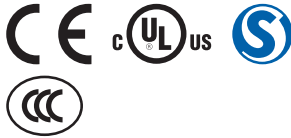

Detailed technical data

Features

Module	Gateway
Fieldbus, industrial network	DeviceNet™
Configuration method	Via software (Flexi Soft Designer)

Interfaces

Fieldbus, industrial network	DeviceNet™
Data transmission rate	≤ 500 kbit/s ¹⁾
Connection type	1 x female connector, Open Style, 5-pin

¹⁾ Depending on cable length.

Electrical data

Protection class	III (EN 61140)
Voltage supply	Via FLEXBUS+
Internal power consumption	≤ 1.6 W ¹⁾

¹⁾ Via FLEXBUS+.

Mechanical data

Dimensions (W x H x D)	22.5 mm x 96.5 mm x 131 mm
Weight	150 g (± 10 %)

Ambient data

Enclosure rating	IP20 (EN 60529)
Ambient operating temperature	-25 °C ... +55 °C
Storage temperature	-25 °C ... +70 °C
Air humidity	≤ 95 %, Non-condensing

Classifications

eCl@ss 5.0	27243001
-------------------	----------

eCI@ss 5.1.4	27243101
eCI@ss 6.0	27243101
eCI@ss 6.2	27243101
eCI@ss 7.0	27243101
eCI@ss 8.0	27243101
eCI@ss 8.1	27243101
eCI@ss 9.0	27243101
eCI@ss 10.0	27243101
eCI@ss 11.0	27243101
eCI@ss 12.0	27243101
ETIM 5.0	EC001449
ETIM 6.0	EC001449
ETIM 7.0	EC001449
ETIM 8.0	EC001449
UNSPSC 16.0901	32151705

Dimensional drawing (Dimensions in mm (inch))

FX0-GCAN, FX0-GDEV

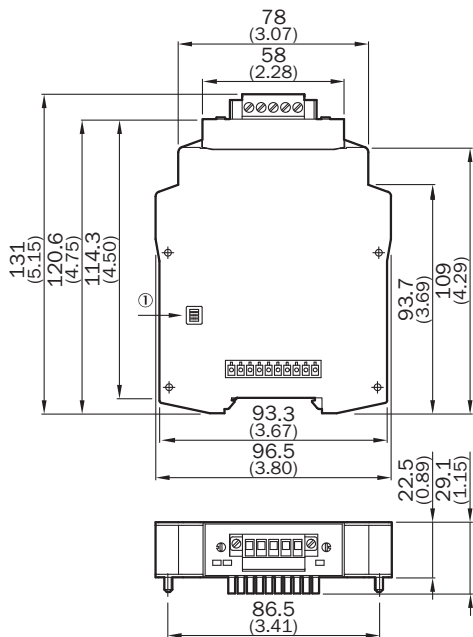

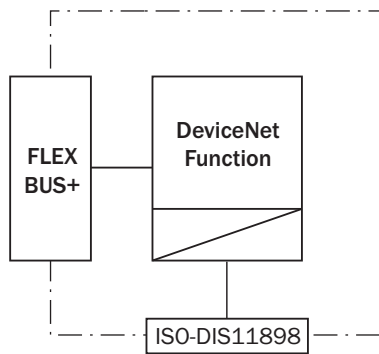

① On the rear

Connection diagram



Recommended accessories

Other models and accessories → www.sick.com/Flexi_Soft

Brief description	Type	Part no.
Others		
 <ul style="list-style-type: none"> • Sub product family: SIM1000 FX • Product category: Programmable devices • Supported products: 2D and 3D LiDAR sensors, pico- und midiCam series, incremental and absolute encoders, Image-based code readers, Fixed mount barcode scanners, RFID read/write device, displacement measurement sensors, Photoelectric sensors, Flexi Soft main module • Processor: Dual-core ARM Cortex-A9 CPU with NEON accelerator • Toolkit: SICK algorithm API • Further functions: FPGA for I/O handling • Connections: Terminal block 1-4, Ethernet, FLEXBUS+ • Enclosure rating: IP20 	SIM1000-0P0B110	1097817
Safety switching amplifier		
 <ul style="list-style-type: none"> • Applications: Output expansion module for OSSDs • Compatible sensor types: Safety sensors with OSSDs • Connection type: Front connector with spring terminals • Restart interlock: no • External device monitoring (EDM): Via path • Outputs: 2 enabling current paths (safe), 1 feedback current path (for use as external device monitoring, not safe) • Housing width: 18 mm 	RLY3-OSSD100	1085343
 <ul style="list-style-type: none"> • Applications: Output expansion module for OSSDs • Compatible sensor types: Safety sensors with OSSDs • Connection type: Front connector with spring terminals • Restart interlock: no • External device monitoring (EDM): Via path • Outputs: 4 enabling current paths (safe), 1 feedback current path (for use as external device monitoring, not safe), 1 signaling current path (not safe) • Housing width: 28 mm 	RLY3-OSSD400	1099971

SICK AT A GLANCE

SICK is one of the leading manufacturers of intelligent sensors and sensor solutions for industrial applications. A unique range of products and services creates the perfect basis for controlling processes securely and efficiently, protecting individuals from accidents and preventing damage to the environment.

We have extensive experience in a wide range of industries and understand their processes and requirements. With intelligent sensors, we can deliver exactly what our customers need. In application centers in Europe, Asia and North America, system solutions are tested and optimized in accordance with customer specifications. All this makes us a reliable supplier and development partner.

Comprehensive services complete our offering: SICK LifeTime Services provide support throughout the machine life cycle and ensure safety and productivity.

For us, that is “Sensor Intelligence.”

WORLDWIDE PRESENCE:

Contacts and other locations –www.sick.com