



# SGS4-F140P7PC1W02

SLG

SWITCHING AUTOMATION LIGHT GRIDS

**SICK**  
Sensor Intelligence.



### Ordering information

Type	Part no.
SGS4-F140P7PC1W02	1214854

Other models and accessories → [www.sick.com/SLG](http://www.sick.com/SLG)



### Detailed technical data

#### Features

<b>Sensor principle</b>	Sender/receiver
<b>Minimum detectable object (MDO)</b>	Parallel beam, 45 mm
<b>Beam separation</b>	40 mm
<b>Optical light exit</b>	Flat
<b>Number of beams</b>	36
<b>Detection height</b>	1,400 mm
<b>Configuration</b>	Without teach button with configuration software
<b>Cross beam/parallel beam</b>	Parallel beam active
<b>Output 1</b>	Output 1 inactive, if light beam interrupted
<b>Automatic teach</b>	Automatic teach inactive
<b>Alignment aid</b>	Without alignment aid
<b>Muting function</b>	Muting function active

#### Mechanics/electronics

<b>Light source</b>	Infrared light
<b>Wave length</b>	950 nm
<b>Supply voltage <math>V_s</math></b>	DC24 V, $\pm 20\%$
<b>Power consumption sender</b>	$\leq 220\text{ mA}^{1)}$
<b>Power consumption receiver</b>	$\leq 70\text{ mA}$
<b>Ripple</b>	$< 5\text{ V}_{pp}$
<b>Output current <math>I_{max.}</math></b>	100 mA
<b>Output load capacitive</b>	100 nF
<b>Output load inductive</b>	1 H
<b>Initialization time</b>	1 s

<sup>1)</sup> , without load.

<sup>2)</sup> Operating in outdoor condition only with a external protection housing.

<b>Dimensions (W x H x D)</b>	25 mm x 1,472.4 mm x 8.2 mm
<b>Connection type</b>	Cable with M8 male connector, 4-pin
<b>Housing material</b>	PMMA
<b>Indication</b>	LED
<b>Synchronization</b>	Optical
<b>Enclosure rating</b>	IP65 2)
<b>Circuit protection</b>	U <sub>V</sub> connections, reverse polarity protected, Output Q short-circuit protected, Interference pulse suppression
<b>Protection class</b>	III
<b>Weight</b>	180 g
<b>Pulse frequency</b>	250 kHz
<b>Aluminum stabilizer</b>	Without stabilizer
<b>Switching output</b>	PNP
<b>Inputs</b>	Teach-in input

1), without load.

2) Operating in outdoor condition only with a external protection housing.

### Performance

<b>Maximum range</b>	10 m <sup>1)</sup>
<b>Minimum range</b>	Parallel beam: ≥ 0 m
<b>Operating range</b>	7 m
<b>Response time</b>	Parallel beam coded version, 38 ms <sup>2)</sup>

1) No reserve for environmental issue and deterioration of the diode.

2) With resistive load.

### Ambient data

<b>EMC</b>	EN 60947-5-2
<b>Ambient operating temperature</b>	-25 °C +55 °C
<b>Ambient storage temperature</b>	-25 °C +70 °C
<b>Ambient light immunity</b>	Direct: 100,000 lx <sup>1)</sup> Indirect: 150,000 lx
<b>Vibration resistance</b>	5 g, 10 Hz ... 55 Hz (IEC 68-2-6)
<b>Shock load</b>	10 g / DIN EN 60068-2-29 / 16 ms

1) Sunlight.

### Classifications

<b>ECl@ss 5.0</b>	27270910
<b>ECl@ss 5.1.4</b>	27270910
<b>ECl@ss 6.0</b>	27270910
<b>ECl@ss 6.2</b>	27270910
<b>ECl@ss 7.0</b>	27270910
<b>ECl@ss 8.0</b>	27270910
<b>ECl@ss 8.1</b>	27270910

<b>ECl@ss 9.0</b>	27270910
<b>ETIM 5.0</b>	EC002549
<b>ETIM 6.0</b>	EC002549
<b>UNSPSC 16.0901</b>	39121528

**Dimensional drawing** (Dimensions in mm (inch))

Sxx-Fxxxxxx1xxx

**Flat, without stabilizer**

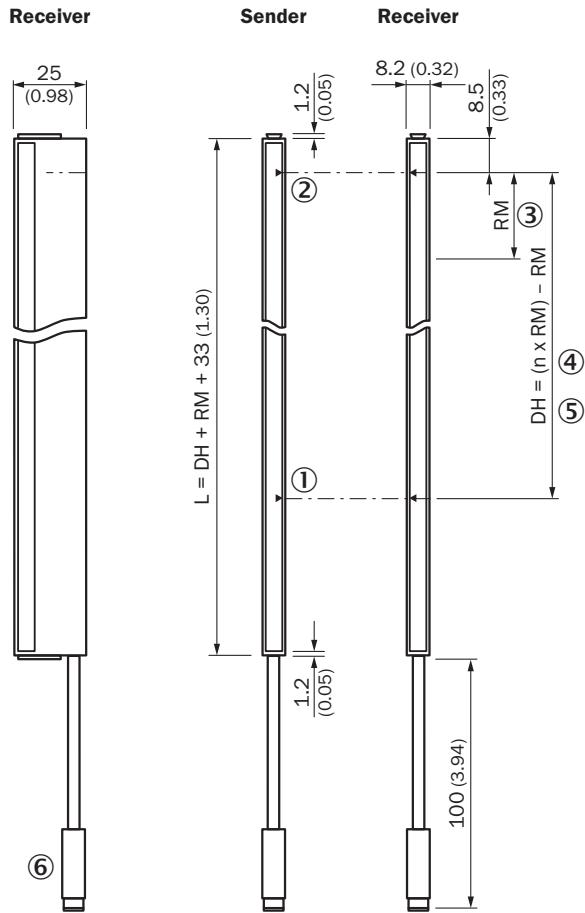

- ① First beam
- ② Last beam
- ③ Beam separation (RM)
- ④ Number of beams (n)
- ⑤ Detection height (DH)
- ⑥ Connection

## Connection type and diagram

Connection type and diagram

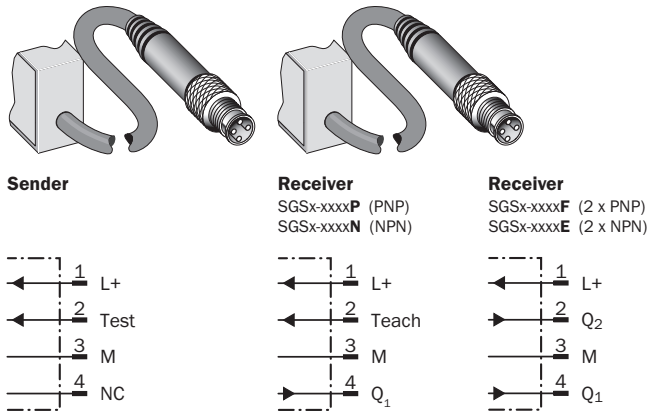

## Concept of operation

Specific features

### Optical synchronization

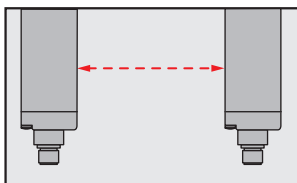

The light grid communicates via the light beams. A cable is not necessary for the optical synchronization.

## Funktionsprinzip



Slim & Flat



- ① Slim model = light emission on narrow side
- ② Flat model = light emission on broad side

Recommended accessories

Other models and accessories → [www.sick.com/SLG](http://www.sick.com/SLG)

	Brief description	Type	Part no.
<b>Mounting brackets and plates</b>			
	Mounting bracket for light grids from a detection height of 600 mm (with slot, recommended for compensation of material extension caused by temperature), mounting position: front, 2x BEF-SLG1, 2x BEF-SLG2	BEF-SLG-SET1	2055427
<b>Plug connectors and cables</b>			
	Head A: female connector, M8, 4-pin, straight, A-coded Head B: Flying leads Cable: Sensor/actuator cable, PVC, unshielded, 2 m	YF8U14-020VA3XLEAX	2095888

## SICK AT A GLANCE

SICK is one of the leading manufacturers of intelligent sensors and sensor solutions for industrial applications. A unique range of products and services creates the perfect basis for controlling processes securely and efficiently, protecting individuals from accidents and preventing damage to the environment.

We have extensive experience in a wide range of industries and understand their processes and requirements. With intelligent sensors, we can deliver exactly what our customers need. In application centers in Europe, Asia and North America, system solutions are tested and optimized in accordance with customer specifications. All this makes us a reliable supplier and development partner.

Comprehensive services complete our offering: SICK LifeTime Services provide support throughout the machine life cycle and ensure safety and productivity.

For us, that is “Sensor Intelligence.”

## WORLDWIDE PRESENCE:

Contacts and other locations –[www.sick.com](http://www.sick.com)