



LL3-DR02

LL3

FIBERS

SICK
Sensor Intelligence.

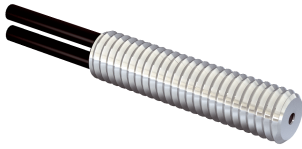

Ordering information

Type	Part no.
LL3-DR02	5308079

Other models and accessories → www.sick.com/LL3

Detailed technical data

Features

Device type	Fibers
Functional principle	Proximity system
For fiber-optic sensor	GLL170(T), WLL180T, WLL80
Fiber length	1,000 mm
Fiber material	Polymethylmethacrylat (PMMA)
Jacket material	Polyethylen (PE)
Fiber head material	Stainless steel ¹⁾
Outer diameter, fiber-optic cable connection	1 mm
Fiber-optic cable cuttable	✓
Thread diameter (housing)	M3
Fiber-optic head design	Threaded sleeve
Fiber arrangement	Multi-fiber – fiber bundle
Core structure	S: 2 x Ø 0,25 mm R: 2 x Ø 0,25 mm ²⁾ Multi-fiber – fiber bundle
Angle of dispersion < 60°	No
Compatibility with infrared light (1,450 nm)	No
Application	High flexible (static), Robotics (dynamic flexible)
Highly flexible/elastic fibers (bend radius 1–4 mm)	Yes
Adapter end sleeves required	Yes
Angle of dispersion	60°
Integrated lens	No
Minimal object diameter	0.015 mm ³⁾
Included with delivery	Mounting, 2 x M3 hexagon nut, 2 x washer, adapter sleeves, BF-WLL160-10 (1.0 mm) adapter sleeves, FC fiber cutter (5304141)
Compatibility tip adapters	No
Special features	Flexible fiber-optic cable, no end sleeve

¹⁾ Stainless steel.

²⁾ C = Coaxial, S = Sender, E = Receiver.

³⁾ Minimum detectable object was determined at optimum measuring distance and optimum setting.

Mechanics/electronics

Bend radius, fibre-optic cable	4 mm
---------------------------------------	------

Ambient operating temperature	-40 °C ... +60 °C
--------------------------------------	-------------------

Classifications

ECl@ss 5.0	27270905
ECl@ss 5.1.4	27270905
ECl@ss 6.0	27270905
ECl@ss 6.2	27270905
ECl@ss 7.0	27270905
ECl@ss 8.0	27270905
ECl@ss 8.1	27270905
ECl@ss 9.0	27270905
ECl@ss 10.0	27270905
ECl@ss 11.0	27270905
ECl@ss 12.0	27270905
ETIM 5.0	EC002651
ETIM 6.0	EC002651
ETIM 7.0	EC002651
ETIM 8.0	EC002651
UNSPSC 16.0901	39121528

Sensing ranges with WLL80

Operating mode 16 µs	16 mm
Operating mode 70 µs	50 mm
Operating mode 250 µs	90 mm
Operating mode 500 µs	110 mm
Operating mode 1 ms	130 mm
Operating mode 2 ms	210 mm
Operating mode 8 ms	320 mm

Sensing ranges with WLL180T

Operating mode 16 µs	18 mm
Operating mode 70 µs	50 mm
Operating mode 250 µs	90 mm
Operating mode 2 ms	200 mm
Operating mode 8 ms	370 mm
Note	Sensing ranges related to fiber-optic sensors with type of light: visible red light

Sensing ranges with GLL170

Operating mode 250 µs	30 mm
------------------------------	-------

Sensing ranges with GLL170T

Operating mode 50 µs	20 mm
Operating mode 250 µs	40 mm

Dimensional drawing (Dimensions in mm (inch))

LL3-DR02

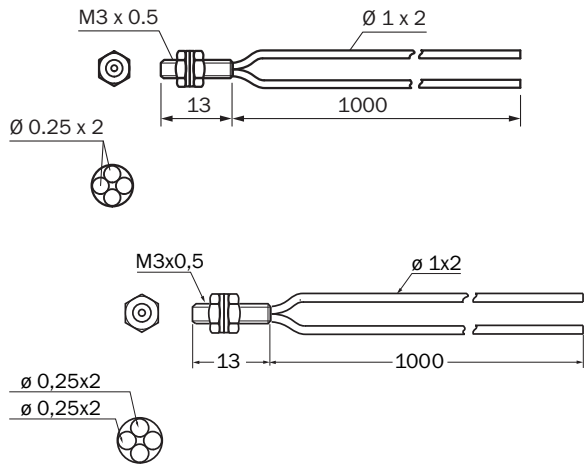

SICK AT A GLANCE

SICK is one of the leading manufacturers of intelligent sensors and sensor solutions for industrial applications. A unique range of products and services creates the perfect basis for controlling processes securely and efficiently, protecting individuals from accidents and preventing damage to the environment.

We have extensive experience in a wide range of industries and understand their processes and requirements. With intelligent sensors, we can deliver exactly what our customers need. In application centers in Europe, Asia and North America, system solutions are tested and optimized in accordance with customer specifications. All this makes us a reliable supplier and development partner.

Comprehensive services complete our offering: SICK LifeTime Services provide support throughout the machine life cycle and ensure safety and productivity.

For us, that is “Sensor Intelligence.”

WORLDWIDE PRESENCE:

Contacts and other locations –www.sick.com