

EN2-2EX1

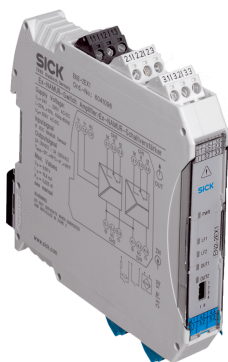

Ordering information

Type	Part no.
EN2-2EX1	6041096

Other models and accessories → www.sick.com/

Detailed technical data

Technical specifications

Accessory family	Power supply modules
Switching output	2 converter relays (1 per channel)
Note	ATEX marking, EX II (1) D [Ex ia Da] IIIC, EX II (1) G [Ex ia Ga] IIC, EX II 3 (1) G Ex nA nC [ia Ga] IIC T4 Gc X
Enclosure rating	IP20
Description	NAMUR isolatig amplifier, Cable fault detection, Switching outputs: 2 NO relay (1 per channel), Supply voltage: 24 V ... 230 V, Voltage type: AC/DC

Classifications

ECl@ss 5.0	27371401
ECl@ss 5.1.4	27371401
ECl@ss 6.0	27070201
ECl@ss 6.2	27070203
ECl@ss 7.0	27070203
ECl@ss 8.0	27070203
ECl@ss 8.1	27070203
ECl@ss 9.0	27070203
ECl@ss 10.0	27070203
ECl@ss 11.0	27070203
ETIM 5.0	EC000216
ETIM 6.0	EC000216
ETIM 7.0	EC000216
UNSPSC 16.0901	39122233

Dimensional drawing (Dimensions in mm (inch))

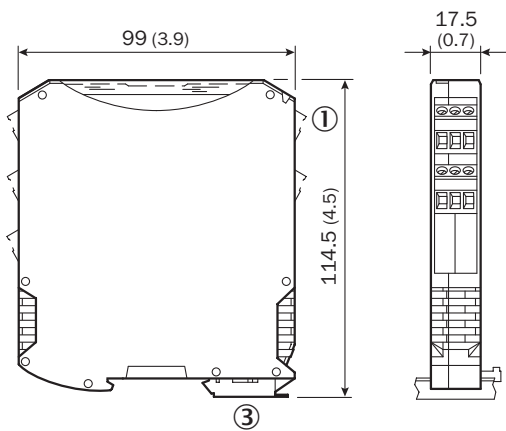

Anschlussschema

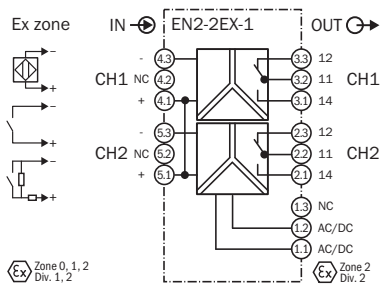

Adjustments

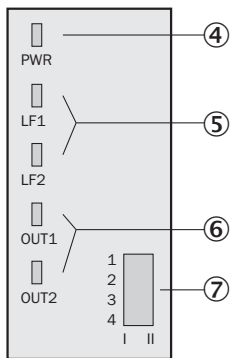

SICK AT A GLANCE

SICK is one of the leading manufacturers of intelligent sensors and sensor solutions for industrial applications. A unique range of products and services creates the perfect basis for controlling processes securely and efficiently, protecting individuals from accidents and preventing damage to the environment.

We have extensive experience in a wide range of industries and understand their processes and requirements. With intelligent sensors, we can deliver exactly what our customers need. In application centers in Europe, Asia and North America, system solutions are tested and optimized in accordance with customer specifications. All this makes us a reliable supplier and development partner.

Comprehensive services complete our offering: SICK LifeTime Services provide support throughout the machine life cycle and ensure safety and productivity.

For us, that is “Sensor Intelligence.”

WORLDWIDE PRESENCE:

Contacts and other locations –www.sick.com