



# STR1-SAMU03P5

## STR1

NON-CONTACT SAFETY SWITCHES

**SICK**  
Sensor Intelligence.



### Ordering information

Type	Part no.
STR1-SAMU03P5	1073201

Other models and accessories → [www.sick.com/STR1](http://www.sick.com/STR1)

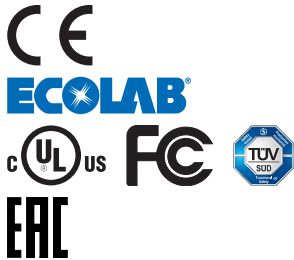

### Detailed technical data

#### Features

<b>System part</b>	Sensor and actuator
<b>Sensor principle</b>	Transponder
<b>Number of safe outputs</b>	2
<b>Auxiliary contact (AUX)</b>	1
<b>Safe switch on distance <math>S_{ao}</math></b>	
Active front sensor surface	14 mm
Active side sensor surface	9 mm
<b>Safe switch off distance <math>S_{ar}</math></b>	28 mm
<b>Active sensor surfaces</b>	3
<b>Actuation directions</b>	5
<b>Coding</b>	Uniquely coded

#### Safety-related parameters

<b>Safety integrity level</b>	SIL3 (IEC 61508), SILCL3 (EN 62061)
<b>Category</b>	Category 4 (EN ISO 13849)
<b>Performance level</b>	PL e (EN ISO 13849)
<b>PFH<sub>D</sub> (mean probability of a dangerous failure per hour)</b>	$5,21 \times 10^{-9}$ (EN ISO 13849)
<b><math>T_M</math> (mission time)</b>	20 years (EN ISO 13849)
<b>Type</b>	Type 4 (EN ISO 14119)
<b>Actuator coding level</b>	High coding level (EN ISO 14119)
<b>Safe state in the event of a fault</b>	At least one safety-related semiconductor output (OSSD) is in the OFF state.

#### Interfaces

<b>Connection type</b>	Cable, 5-wire
Length of cable	3 m

Cable material	PVC
<b>Diagnostics indicator</b>	✓
<b>Status display</b>	✓

#### Electrical data

<b>Protection class</b>	III (IEC 61140)
<b>Classification according to cULus</b>	Class 2
<b>Supply voltage <math>V_s</math></b>	24 V DC (19.2 V DC ... 28.8 V DC)
<b>Power consumption</b>	50 mA
<b>Type of output</b>	Semiconductor (OSSD)
<b>Output current</b>	≤ 100 mA
<b>Response time</b>	40 ms <sup>1)</sup>
<b>Enable time</b>	100 ms <sup>1) 2)</sup>
<b>Risk time</b>	80 ms <sup>1) 3)</sup>
<b>Switch-on time</b>	4)

<sup>1)</sup> In a cascade each downstream safety switch increases the response time of the system. Other response times see operating instructions.

<sup>2)</sup> Response time on approach to the enable zone.

<sup>3)</sup> Detection time for internal oder external faults (e.g., short-circuit or cross-circuit of output signal switching devices). Follow the detailed information in the operating instructions.

<sup>4)</sup> The stated time applies for one sensor after application of the supply voltage to the safety switch. In case of a cascade 0.1 s must be added per sensor. For uniquely coded or permanently coded sensors 0.5 s must be added additionally per taught-in actuator.

#### Mechanical data

<b>Dimensions (W x H x D)</b>	40 mm x 18 mm x 26 mm
<b>Weight</b>	150 g
<b>Housing material</b>	VISTAL®

#### Ambient data

<b>Enclosure rating</b>	IP67 (EN 60529) IPX9K (ISO 20653)
<b>Ambient operating temperature</b>	-10 °C ... +70 °C
<b>Storage temperature</b>	-25 °C ... +70 °C
<b>Vibration resistance</b>	10 Hz ... 55 Hz, 1 mm (IEC 60068-2-6)
<b>Shock resistance</b>	30 g, 11 ms (IEC 60068-2-27)
<b>EMC</b>	EN IEC 61326-3-1 EN IEC 60947-5-2 EN IEC 60947-5-3

#### Classifications

<b>ECl@ss 5.0</b>	27272403
<b>ECl@ss 5.1.4</b>	27272403
<b>ECl@ss 6.0</b>	27272403
<b>ECl@ss 6.2</b>	27272403
<b>ECl@ss 7.0</b>	27272403
<b>ECl@ss 8.0</b>	27272403
<b>ECl@ss 8.1</b>	27272403
<b>ECl@ss 9.0</b>	27272403

<b>ETIM 5.0</b>	EC001829
<b>ETIM 6.0</b>	EC001829
<b>UNSPSC 16.0901</b>	39122205

**Dimensional drawing** (Dimensions in mm (inch))

Sensor with cable

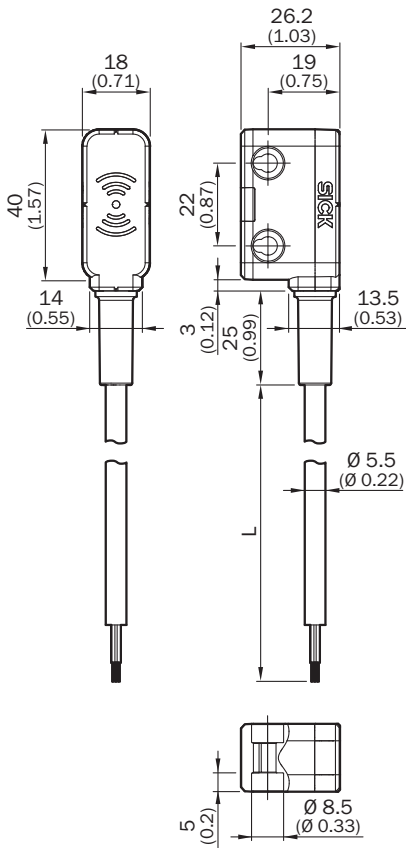

“Mini” actuator

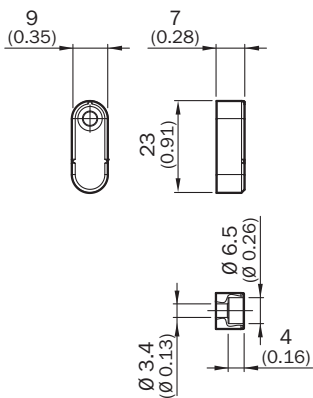

## Response range

“Flat”/“Mini” actuator, active side sensor surface

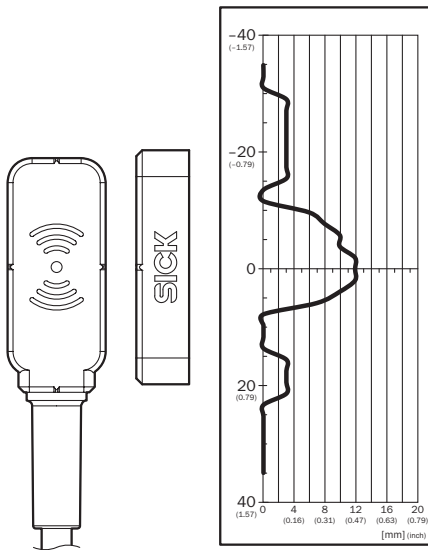

Safe switch on distance  $S_{A0}$  9 mm. Pay attention to boundary areas in case of parallel approach: If the actuator moves laterally in relation to the surface of the sensor, a minimum distance of 4 mm must be maintained. This distance will prevent premature triggering due to the side approach areas.

“Flat”/“Mini” actuator, active front sensor surface

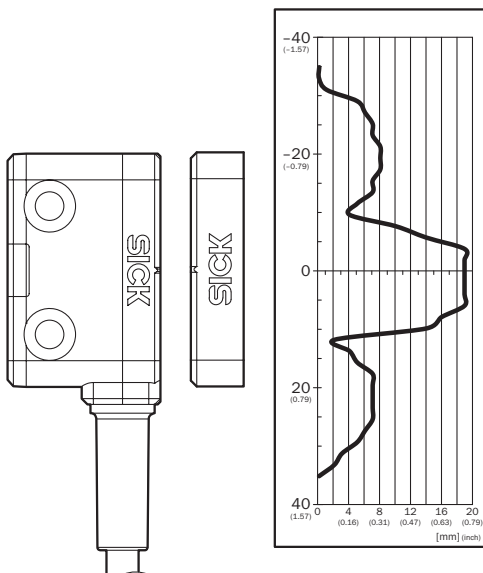

Safe switch on distance  $S_{A0}$  14 mm. Pay attention to boundary areas in case of parallel approach: If the actuator moves laterally in relation to the surface of the sensor, a minimum distance of 10 mm must be maintained. This distance will prevent premature triggering due to the side approach areas.

Connection diagram

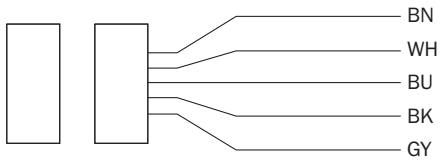

Brown	Voltage supply 24 V DC
White	OSSD 1
Blue	Voltage supply 0 V DC
Black	OSSD 2
Grey	Aux output (not safe)

Recommended accessories

Other models and accessories → [www.sick.com/STR1](http://www.sick.com/STR1)

	Brief description	Type	Part no.
Nuts and screws			
	10 pieces	Safety screws M3 x 12	5333569

## SICK AT A GLANCE

SICK is one of the leading manufacturers of intelligent sensors and sensor solutions for industrial applications. A unique range of products and services creates the perfect basis for controlling processes securely and efficiently, protecting individuals from accidents and preventing damage to the environment.

We have extensive experience in a wide range of industries and understand their processes and requirements. With intelligent sensors, we can deliver exactly what our customers need. In application centers in Europe, Asia and North America, system solutions are tested and optimized in accordance with customer specifications. All this makes us a reliable supplier and development partner.

Comprehensive services complete our offering: SICK LifeTime Services provide support throughout the machine life cycle and ensure safety and productivity.

For us, that is “Sensor Intelligence.”

## WORLDWIDE PRESENCE:

Contacts and other locations –[www.sick.com](http://www.sick.com)