

UM18-2 Core

Ultrasonic sensor

SICK
Sensor Intelligence.



Described product

UM18-2 Core

Manufacturer

SICK AG
Erwin-Sick-Str. 1
79183 Waldkirch
Germany

Legal information

This work is protected by copyright. Any rights derived from the copyright shall be reserved for SICK AG. Reproduction of this document or parts of this document is only permissible within the limits of the legal determination of Copyright Law. Any modification, abridgment or translation of this document is prohibited without the express written permission of SICK AG.

The trademarks stated in this document are the property of their respective owner.

© SICK AG. All rights reserved.

Original document

This document is an original document of SICK AG.



Contents

1	About this document.....	5
1.1	Information on the operating instructions.....	5
1.2	Symbols and document conventions.....	5
1.3	Further information.....	5
2	Safety information.....	7
2.1	Intended use.....	7
2.2	Improper use.....	7
2.3	Cybersecurity.....	7
2.4	Limitation of liability.....	7
2.5	Modifications and conversions.....	8
2.6	Requirements for skilled persons and operating personnel.....	8
2.7	Operational safety and specific hazards.....	8
2.8	UL conformity.....	9
3	Product description.....	10
3.1	Scope of delivery.....	10
3.2	Type code.....	10
3.3	Product overview.....	10
4	Transport and storage.....	12
4.1	Transport.....	12
4.2	Unpacking.....	12
4.3	Transport inspection.....	12
4.4	Storage.....	12
5	Mounting.....	13
5.1	Mounting instructions.....	13
5.2	Arranging multiple devices.....	13
5.2.1	Mounting distances.....	13
5.3	Alignment of the device.....	13
5.4	Mounting the device.....	13
6	Electrical installation.....	14
6.1	Wiring instructions.....	14
6.2	Prerequisites for safe operation of the device.....	14
6.3	Pin assignment.....	16
7	Operation.....	18
7.1	Display elements.....	18
7.2	Digital output 1 teach-in.....	18
7.2.1	Factory settings of the digital output.....	18
7.2.2	Teaching in switching point (Single Point Mode).....	18
7.2.3	Teaching in switching window (Window Mode).....	19
7.2.4	Teaching in background (Window Mode \pm 8 %).....	19

7.2.5	Adjusting the N/C contact and N/O contact.....	20
7.3	Analog output teach-in.....	20
7.3.1	Factory settings of the analog output.....	20
7.3.2	Scaling analog output.....	20
7.3.3	Adjusting the rising or falling output characteristic.....	21
7.4	Resetting the device to factory settings.....	21
7.5	Activating and deactivating teach-in.....	21
7.6	IO-Link.....	21
7.7	Establishing a connection to SOPAS ET.....	22
7.8	Connect+.....	22
8	Maintenance.....	23
8.1	Maintenance plan.....	23
8.2	Cleaning.....	23
9	Troubleshooting.....	24
9.1	General faults.....	24
9.2	Repairs.....	24
9.3	Returns.....	24
9.4	Disposal.....	24
10	Technical data.....	25
10.1	Mechanics/Electronics.....	25
10.2	Dimensional drawings.....	26
10.3	Performance.....	26
10.4	Interfaces.....	27
10.5	Ambient data.....	27
10.6	Detection ranges.....	28
11	Accessories.....	32
12	Annex.....	33
12.1	Declarations of conformity and certificates.....	33
12.2	Licenses.....	33

1 About this document

1.1 Information on the operating instructions

Read these operating instructions carefully before starting any work in order to familiarize yourself with the product and its functions.

The operating instructions are an integral part of the product and should remain accessible to the personnel at all times. When handing this product over to a third party, include these operating instructions.

These operating instructions do not provide information on the handling and safe operation of the machine or system in which the product is integrated. Information on this can be found in the operating instructions for the machine or system.

1.2 Symbols and document conventions

Warnings and other notes



DANGER

Indicates a situation presenting imminent danger, which will lead to death or serious injuries if not prevented.



WARNING

Indicates a situation presenting possible danger, which may lead to death or serious injuries if not prevented.



CAUTION

Indicates a situation presenting possible danger, which may lead to moderate or minor injuries if not prevented.



NOTICE

Indicates a situation presenting possible danger, which may lead to property damage if not prevented.



NOTE

Highlights useful tips and recommendations as well as information for efficient and trouble-free operation.

Instructions to action

- ▶ The arrow denotes instructions to action.
- 1. The sequence of instructions is numbered.
- 2. Follow the order in which the numbered instructions are given.
- ✓ The tick denotes the results of an action.

1.3 Further information

More information can be found on the product page.

The page can be accessed via the **SICK Product ID: pid.sick.com/{P/N}/{S/N}**

{P/N} corresponds to the part number of the product, see type label.

{S/N} corresponds to the serial number of the product, see type label (if indicated).

The following information is available depending on the product:

- Data sheets
- This document in all available language versions
- CAD files and dimensional drawings
- Certificates (e.g., declaration of conformity)
- Other publications
- Software
- Accessories

2 Safety information

2.1 Intended use

The UM18-2 ultrasonic sensor is used for non-contact detection and distance measurement.

SICK AG assumes no liability for losses or damage arising from the use of the product, either directly or indirectly. This applies to use of the product that does not conform to its intended purpose and is neither described nor mentioned in this documentation.

2.2 Improper use

Any use outside of the stated areas, in particular use outside of the technical specifications and the requirements for intended use, will be deemed to be incorrect use.

- The device does not constitute a safety component in accordance with the respective applicable safety standards for machines.
- The device must not be used in explosion-hazardous areas, in corrosive environments or under extreme environmental conditions.
- Any use of accessories not specifically approved by SICK AG is at your own risk.



WARNING

Danger due to improper use!

Any improper use can result in dangerous situations.

Therefore, observe the following information:

- Product should be used only in accordance with its intended use.
- All information in the documentation must be strictly observed.
- Shut down the product immediately in case of damage.

2.3 Cybersecurity

Overview

To protect against cybersecurity threats, it is necessary to continuously monitor and maintain a comprehensive cybersecurity concept. A suitable concept consists of organizational, technical, procedural, electronic, and physical levels of defense and considers suitable measures for different types of risks. The measures implemented in this product can only support protection against cybersecurity threats if the product is used as part of such a concept.

You will find further information at www.sick.com/psirt, e.g.:

- General information on cybersecurity
- Contact option for reporting vulnerabilities
- Information on known vulnerabilities (security advisories)

2.4 Limitation of liability

Relevant standards and regulations, the latest technological developments, and our many years of knowledge and experience have all been taken into account when compiling the data and information contained in these operating instructions. The manufacturer accepts no liability for damage caused by:

- Non-adherence to the product documentation (e.g., operating instructions)
- Incorrect use
- Use of untrained staff
- Unauthorized conversions or repair

- Technical modifications
- Use of unauthorized spare parts, consumables, and accessories

2.5 Modifications and conversions



NOTICE

Modifications and conversions to the device may result in unforeseeable dangers.

Interrupting or modifying the device or SICK software will invalidate any warranty claims against SICK AG. This applies in particular to opening the housing, even as part of mounting and electrical installation.

2.6 Requirements for skilled persons and operating personnel



WARNING

Risk of injury due to insufficient training.

Improper handling of the device may result in considerable personal injury and material damage.

- All work must only ever be carried out by the stipulated persons.

The following qualifications are required for various activities:

Table 1: Activities and technical requirements

Activities	Qualification
Mounting, maintenance	<ul style="list-style-type: none"> ■ Basic practical technical training ■ Knowledge of the current safety regulations in the workplace
Electrical installation, device replacement	<ul style="list-style-type: none"> ■ Practical electrical training ■ Knowledge of current electrical safety regulations ■ Knowledge of the operation and control of the devices in their particular application
Commissioning, configuration	<ul style="list-style-type: none"> ■ Basic knowledge of the computer operating system used ■ Basic knowledge of the design and setup of the described connections and interfaces ■ Basic knowledge of data transmission
Operation of the device for the particular application	<ul style="list-style-type: none"> ■ Knowledge of the operation and control of the devices in their particular application ■ Knowledge of the software and hardware environment for the particular application

2.7 Operational safety and specific hazards

Please observe the safety notes and the warnings listed here and in other sections of this product documentation to reduce the possibility of risks to health and avoid dangerous situations.

**WARNING****Electrical voltage!**

Electrical voltage can cause severe injury or death.

- Work on electrical systems must only be performed by qualified electricians.
- The power supply must be disconnected when attaching and detaching electrical connections.
- The product must only be connected to a voltage supply as set out in the requirements in the operating instructions.
- National and regional regulations must be complied with.
- Safety requirements relating to work on electrical systems must be complied with.

**WARNING****Risk of injury and damage caused by potential equalization currents!**

Improper grounding can lead to dangerous equipotential bonding currents, which may in turn lead to dangerous voltages on metallic surfaces, such as the housing. Electrical voltage can cause severe injury or death.

- Work on electrical systems must only be performed by qualified electricians.
- Follow the notes in the operating instructions.
- Install the grounding for the product and the system in accordance with national and regional regulations.

2.8 UL conformity



NFPA79 applications only. Adapters including field wiring cables are available.

More information can be found on the product page:

The page can be accessed via the **SICK Product ID: pid.sick.com/{P/N}/{S/N}**

{P/N} corresponds to the part number of the product, see type label.

{S/N} corresponds to the serial number of the product, see type label (if indicated).

3 Product description

3.1 Scope of delivery

Table 2: Scope of delivery

No. of units	Component	Note
1	Product in the type ordered	-
1	Printed safety notes, multilingual	Brief information and general safety notes

The actual scope of delivery may differ for special designs, additional orders or due to the latest technical changes.

3.2 Type code

Type code structure

UM18 – a b c d e f g h i

Position	Description	Characteristic
a	Generation	2: 2. Generation
b	Principle of operation	1: Button operation
c	Detection range, mounting distance (UD)	7: 20 mm ... 150 mm, 250 mm 1: 30 mm ... 250 mm, 350 mm 2: 65 mm ... 350 mm, 600 mm 8: 120 mm ... 1000 mm, 1300 mm
d	Connection type	1: male connector, M12, 5-pin
e	Housing version	2: Nickel-plated brass, without display 6: Plastic PBT, without display
f	Output function	1: 1 PNP digital output 5: 1 NPN digital output 6: 1 analog current interface 7: 1 analog voltage interface
g	IO-Link, communication	1: No IO-Link 2: IO-Link
h	Performance	0: Core 1: Pro
i	Sending axis	1: Straight 2: Angled

3.3 Product overview

Product overview

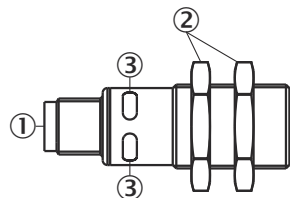

Figure 1: Product overview, example: UM18-2xxxxxx1

- ① Male connector, M12, 5-pin
- ② Fixing nuts, width 24 mm
- ③ Status LEDs

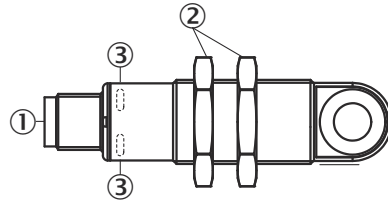

Figure 2: Product overview, example: UM18-2xxxxxx2

- ① Male connector, M12, 5-pin
- ② Fixing nuts, width 24 mm
- ③ Status LEDs

Further topics

- [Dimensional drawings](#)

4 Transport and storage

4.1 Transport

**NOTICE****Damage due to improper transport!**

- The product must be packaged with protection against shock and damp.
 - Recommendation: Use the original packaging.
 - Note the symbols on the packaging.
 - Do not remove packaging until immediately before you start mounting.
-

4.2 Unpacking

- To protect the device against condensation, allow it to equilibrate with the ambient temperature before unpacking if necessary.
- Handle the device with care and protect it from mechanical damage.

4.3 Transport inspection

Immediately upon receipt in Goods-in, check the delivery for completeness and for any damage that may have occurred in transit. In the case of transit damage that is visible externally, proceed as follows:

- Do not accept the delivery or only do so conditionally.
 - Note the scope of damage on the transport documents or on the transport company's delivery note.
 - File a complaint.
-

**NOTE**

Complaints regarding defects should be filed as soon as these are detected. Damage claims are only valid before the applicable complaint deadlines.

4.4 Storage

- Do not store outdoors.
- Store in a place protected from moisture and dust.
- Recommendation: Use the original packaging.
- Do not expose to any aggressive substances.
- Protect from sunlight.
- Avoid mechanical shocks.
- Storage temperature: [see "Technical data", page 25](#).
- For storage periods of longer than 3 months, check the general condition of all components and packaging on a regular basis.

5 Mounting

5.1 Mounting instructions

- Observe the technical data.
- To prevent condensation, avoid exposing the device to rapid changes in temperature.
- The mounting site has to be designed for the weight of the device.

5.2 Arranging multiple devices

5.2.1 Mounting distances

To use multiple products, observe the following mounting distances. If you undercut the specified mounting distance, activate synchronization or multiplex operation.

Table 3: Mounting distances

Type	Parallel	Opposite
UM18-217x	> 250 mm	> 1300 mm
UM18-211x	> 350 mm	> 2500 mm
UM18-212x	> 400 mm	> 2500 mm
UM18-218x	> 700 mm	> 4000 mm

5.3 Alignment of the device

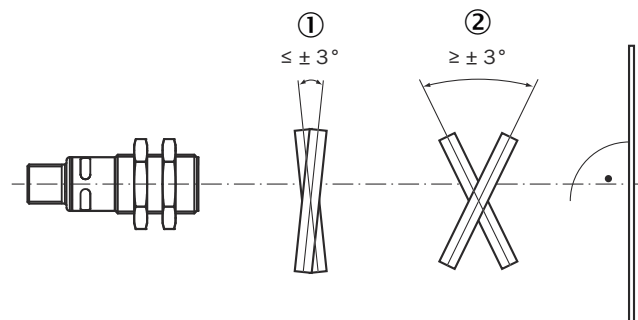

Figure 3: Aligning the product for smooth and rough surfaces

- ① Smooth surface: Angle $\leq 90^\circ \pm 3^\circ$ between the sensor axis and object surface
- ② Rough surface: Angle $\geq 90^\circ \pm 3^\circ$ between the sensor axis and object surface

5.4 Mounting the device

Approach

1. Select a suitable mounting location. Consider the specifications in the technical data when doing so.
2. Mount the device in a suitably prepared bracket using the fixing holes provided.
3. Tighten the fixing nuts with a torque of max. 1 Nm.

6 Electrical installation

6.1 Wiring instructions

**NOTE**

Pre-assembled cables can be found on the product page.

The page can be accessed via the **SICK Product ID: pid.sick.com/{P/N}/{S/N}**

{P/N} corresponds to the part number of the product, see type label.

{S/N} corresponds to the serial number of the product, see type label (if indicated).

**NOTICE****Faults during operation and defects in the device or the system**

Incorrect wiring may result in operational faults and defects.

- Follow the wiring notes precisely.
-

The enclosure rating stated in the technical data is achieved only with a screwed plug connector or protective cap.

Connect the connecting cables in a de-energized state. Do not switch on the supply voltage until installation is complete and all connecting cables are connected to the device and control.

The supply voltage must be as specified in the technical data, [see "Technical data", page 25](#).

When commissioning, protect the device from moisture and contamination.

6.2 Prerequisites for safe operation of the device

**WARNING****Risk of injury and damage caused by electrical current!**

As a result of equipotential bonding currents between the device and other grounded devices in the system, faulty grounding of the device can give rise to the following dangers and faults:

- Dangerous voltages are applied to the metal housings.
- Devices will behave incorrectly or be destroyed.
- Cable shielding will be damaged by overheating and cause cable fires.

Remedial measures

- Only skilled electricians should be permitted to carry out work on the electrical system.
 - If the cable insulation is damaged, disconnect the voltage supply immediately and have the damage repaired.
 - Ensure that the ground potential is the same at all grounding points.
 - Where local conditions do not meet the requirements for a safe earthing method, take appropriate measures. For example, ensure low-impedance and current-carrying equipotential bonding.
-

The device is connected to the peripheral devices (any local trigger sensor(s), system controller) via shielded cables. The cable shield – for the data cable, for example – rests against the metal housing of the device.

The device can be grounded through the cable shield or through a blind tapped hole in the housing, for example.

If the peripheral devices have metal housings and the cable shields are also in contact with their housings, it is assumed that all devices involved in the installation have the **same ground potential**.

This is achieved by complying with the following conditions:

- Mounting the devices on conductive metal surfaces
- Correctly grounding the devices and metal surfaces in the system
- If necessary: low-impedance and current-carrying equipotential bonding between areas with different ground potentials

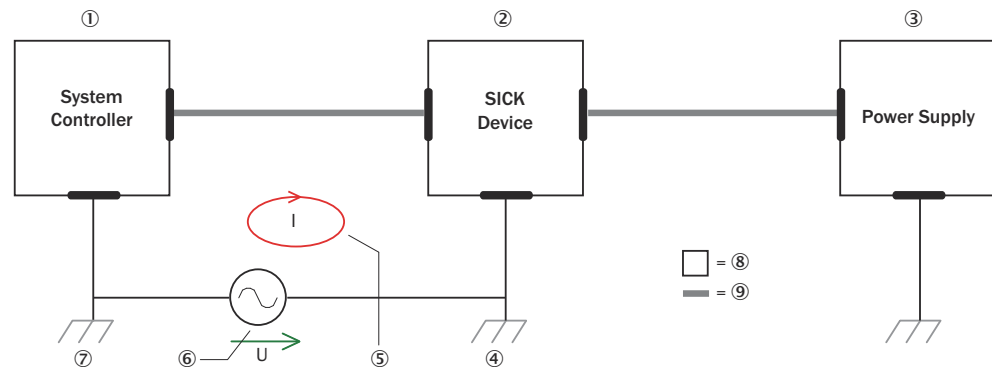

Figure 4: Example: Occurrence of equipotential bonding currents in the system configuration

- ① System controller
- ② Device
- ③ Voltage supply
- ④ Grounding point 2
- ⑤ Closed current loop with equalizing currents via cable shield
- ⑥ Ground potential difference
- ⑦ Grounding point 1
- ⑧ Metal housing
- ⑨ Shielded electrical cable

If these conditions are not fulfilled, equipotential bonding currents can flow along the cable shielding between the devices due to differing ground potentials and cause the hazards specified. This is, for example, possible in cases where there are devices within a widely distributed system covering several buildings.

Remedial measures

The most common solution to prevent equipotential bonding currents on cable shields is to ensure low-impedance and current-carrying equipotential bonding. If this equipotential bonding is not possible, the following solution approaches serve as a suggestion.



NOTICE

We expressly advise against opening up the cable shields. This would mean that the EMC limit values can no longer be complied with and that the safe operation of the device data interfaces can no longer be guaranteed.

Measures for widely distributed system installations

On widely distributed system installations with correspondingly large potential differences, the setting up of local islands and connecting them using commercially available **electro-optical signal isolators** is recommended. This measure achieves a high degree of resistance to electromagnetic interference.

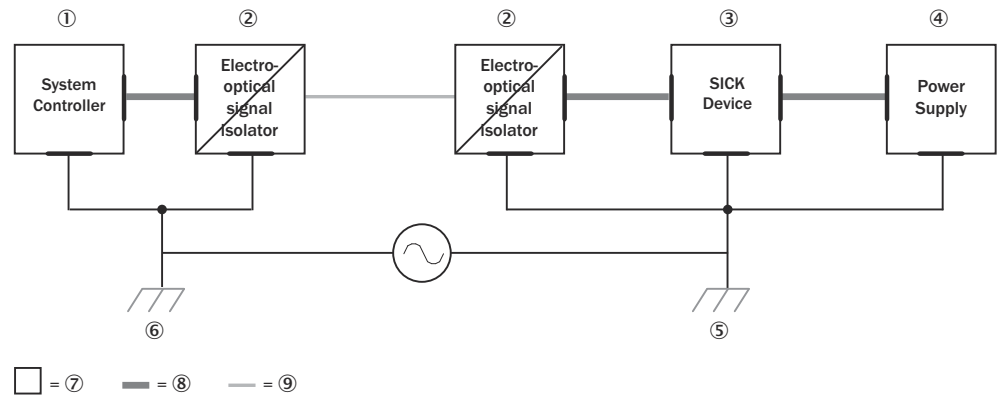

Figure 5: Example: Prevention of equipotential bonding currents in the system configuration by the use of electro-optical signal isolators

- ① System controller
- ② Electro-optical signal isolator
- ③ Device
- ④ Voltage supply
- ⑤ Grounding point 2
- ⑥ Grounding point 1
- ⑦ Metal housing
- ⑧ Shielded electrical cable
- ⑨ Optical fiber

The use of electro-optical signal isolators between the islands isolates the ground loop. Within the islands, a stable equipotential bonding prevents equalizing currents on the cable shields.

Measures for small system installations

For smaller installations with only slight potential differences, insulated mounting of the device and peripheral devices may be an adequate solution.

Even in the event of large differences in the ground potential, ground loops are effectively prevented. As a result, equalizing currents can no longer flow via the cable shields and metal housing.



NOTICE

The voltage supply for the device and the connected peripheral devices must also guarantee the required level of insulation.

Under certain circumstances, a tangible potential can develop between the insulated metal housings and the local ground potential.

6.3 Pin assignment

UM18-2xxx1/5xxx

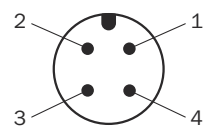

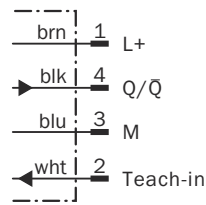

Figure 6: Male connector, M12, 4-pin

Table 4: Pin assignment UM18-2xxx1/5xxx

Contact	Labels	Wire color	Signal description
1	L+	Brown	Supply voltage, see "Mechanics/Electronics", page 25
2	Teach-in	White	Teach-in
3	M	Blue	Supply voltage: 0 V
4	Q/\bar{Q}	Black	Digital output / inverted digital output

UM18-2xxx6/7xxx

Figure 7: Male connector, M12, 4-pin

Table 5: Pin assignment UM18-2xxx6/7xxx

Contact	Labels	Wire color	Signal description
1	L+	Brown	Supply voltage
2	Q_A	White	Analog output
3	M	Blue	Supply voltage: 0 V
4	Teach-in	Black	Teach-in

7 Operation

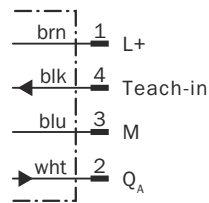
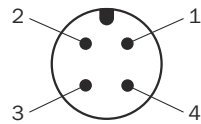
7.1 Display elements

Overview

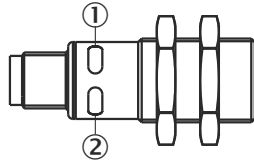

Figure 8: Status LEDs UM18-2xxxxxx1 (example)

- ① LED 1
- ② LED 2

Status LEDs

Status LED	Status (color)	Status
LED 1	● (Green)	Supply voltage active, product is ready for operation
LED 2	● (Orange)	Digital output: Digital output is active Analog output: Object is in scaling range
	☀ (Orange) Flashes quickly for 3 seconds.	Teach-in <ul style="list-style-type: none"> • No object detected • Object outside the detection range • First switching point is within and second switching point is outside the detection range ¹⁾ • Scaling < 1 mm is taught-in ²⁾ The existing switching points are retained.

● = Lights up; ☀ = Flashes; ○ = Does not light up.

- 1) Applies to the switching window and background switching functions.
- 2) Applies when teaching in the analog output.

7.2 Digital output 1 teach-in

7.2.1 Factory settings of the digital output

- N/O contact

7.2.2 Teaching in switching point (Single Point Mode)

Overview

When the object is located below the taught-in switching point, the digital output is active.

Approach

Teaching in the switching point (distance to object as switching point)

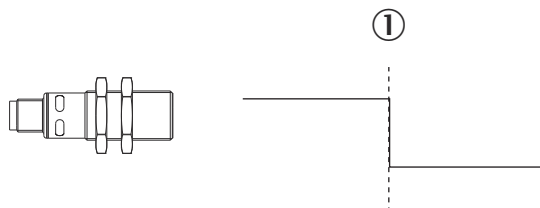

1. Position the object at ①.

2. Apply L+ at **Teach-in** for 3 seconds until both LEDs are flashing simultaneously.
✓ Both LEDs flash alternately.
3. Apply L+ at **Teach-in** for 1 second.
✓ The switching point is taught in. The product automatically switches to normal operation mode.

Teaching in switching point (distance to object + 8 % as switching point)

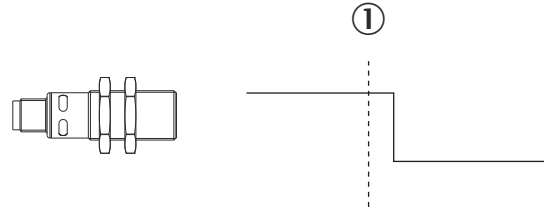

1. Position the object at ①.
2. Apply L+ at **Teach-in** for 3 seconds until both LEDs are flashing simultaneously.
✓ Both LEDs flash alternately.
3. Apply L+ at **Teach-in** for 3 seconds until both LEDs are again flashing alternately.
✓ The switching point is taught in. The product automatically switches to normal operation mode.

7.2.3 Teaching in switching window (Window Mode)

Overview

When the object is located within the taught-in switching window, the digital output is active.

Approach

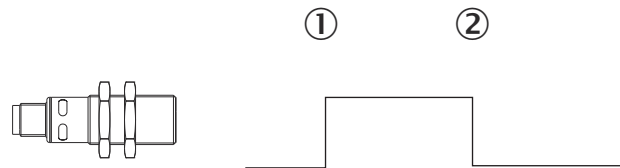

Figure 9: Window Mode

1. Position the object at ①.
2. Apply L+ at **Teach-in** for 3 seconds until both LEDs are flashing simultaneously.
✓ Both LEDs flash alternately.
3. Position the object at ②.
✓ Both LEDs flash alternately.
4. Apply L+ at **Teach-in** for 1 second.
✓ The switching points are taught in. The product automatically switches to normal operation mode.

7.2.4 Teaching in background (Window Mode $\pm 8\%$)

Overview

When the object is located either below the taught-in background - 8 % or above the taught-in background + 8 %, the digital output is active.

Approach

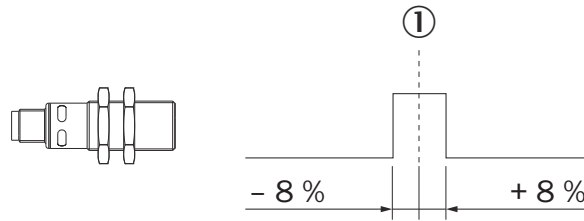

Figure 10: Window Mode $\pm 8 \%$

1. Position the background at ①.
2. Apply L+ at Teach-in for 3 seconds until both LEDs are flashing simultaneously.
 - ✓ Both LEDs flash alternately.
3. Apply L+ at Teach-in for 10 seconds until both LEDs stop flashing.
 - ✓ The background is taught in. The product automatically switches to normal operation mode.

7.2.5 Adjusting the N/C contact and N/O contact

Approach

1. Apply L+ at Teach-in for 13 seconds until both LEDs flash alternately.
 - ✓ Green LED flashes.
 - ✓ N/O: Orange LED lights up.
 - ✓ N/C: Orange LED does not light up.
2. To change the setting, apply L+ at Teach-in for 1 second.
 - ✓ Orange LED changes its status.
3. Wait 10 seconds.
 - ✓ Green LED no longer flashes.
 - ✓ N/C or N/O is set. The product automatically switches to normal operation mode.

7.3 Analog output teach-in

7.3.1 Factory settings of the analog output

- Rising output characteristic from minimum to maximum operating range

7.3.2 Scaling analog output

Overview

To scale the analog output, teach in a close sensor and distant sensor scaling limit. If the distant sensor scaling limit is taught in first and then the close sensor scaling limit, the limits are reversed internally.

Approach

Teaching in the scaling limits (UM18-xxxxx6/7xxx)

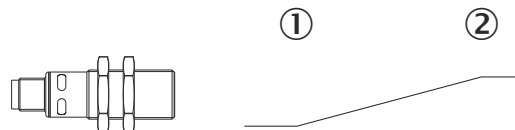

1. Position the object at ①.
2. Apply L+ at Teach-in for 3 seconds until both LEDs are flashing simultaneously.
 - ✓ Both LEDs flash alternately.
3. Position the object at ②.

4. Apply L+ at **Teach-in** for 1 second.
- ✓ The scaling is taught in. The product automatically switches to normal operation mode.

7.3.3 Adjusting the rising or falling output characteristic

Approach

Adjusting output characteristics (UM18-xxxxx6/7xxx)

1. Apply L+ at **Teach-in** for 13 seconds until both LEDs flash alternately.
- ✓ Green LED flashes.
- ✓ Rising: Orange LED lights up.
- ✓ Falling: Orange LED does not light up.
2. To change the setting, apply L+ at **Teach-in** for 1 second.
- ✓ Orange LED changes its status.
3. Wait 10 seconds.
- ✓ Green LED no longer flashes.
- ✓ The rising or falling output characteristic is set. The product automatically switches to normal operation mode.

7.4 Resetting the device to factory settings

Approach

1. Switch off the supply voltage.
2. Apply L+ at **Teach-in**.
3. Switch on the supply voltage.
4. Wait 13 s until both LEDs stop flashing
5. To apply the factory settings, separate L+ from **Teach-in** before switching off the supply voltage.
- ✓ The product is reset to the factory settings. The product automatically switches to normal operation mode.

7.5 Activating and deactivating teach-in

Approach

1. Switch off the supply voltage.
2. Apply L+ at **Teach-in**.
3. Switch on the supply voltage.
4. Wait 3 seconds until both LEDs are flashing simultaneously.
- ✓ Green LED flashes.
- ✓ Activated: Orange LED lights up.
- ✓ Deactivated: Orange LED does not light up.
5. To change the setting, apply L+ at **Teach-in** for 1 second.
- ✓ Orange LED changes its status.
6. Wait 10 seconds.
- ✓ Green LED no longer flashes.
- ✓ Teach-in and is activated or deactivated. The product automatically switches to normal operation mode.

7.6 IO-Link

Depending on the product type, the product can exchange process data and parameters via IO-Link. To do this, connect the product to a suitable IO-Link Master. A sensor-specific device description file (IODD) is required in the IO-Link Master. The IODD and a supplementary information document are available on the product page.

The page can be accessed via the **SICK Product ID: pid.sick.com/{P/N}/{S/N}**

{P/N} corresponds to the part number of the product, see type label.

{S/N} corresponds to the serial number of the product, see type label (if indicated).

7.7 Establishing a connection to SOPAS ET

Overview

The SOPAS Engineering Tool (SOPAS ET) software is suitable for parameterization as well as for service and diagnostics purposes.

Prerequisites

- Product type with IO-Link
- A computer with the SOPAS ET software installed on it, and a free USB 2.0 compatible port



NOTE

The most up-to-date version of the SOPAS ET software can be downloaded from www.sick.com/SOPAS_ET. The respective system requirements for installing SOPAS ET are also specified there.

-
- SICK SiLink2 Master (available as accessory)
 - Connection cable with M12 male and female connectors, 4-pin (available as accessory)
 - Device description file (SDD)



NOTE

The SDD can be installed in SOPAS ET or via the SICK website. Follow the instructions in SOPAS ET.

Approach

1. Connect the product to the SiLink2 Master via the male connector or an additional connection cable.
2. Connect the SiLink2 Master to the computer using the supplied USB cable.
3. Switch on and start the computer.
4. To ensure an adequate voltage supply to the product, also connect the enclosed wall plug to the SiLink2 Master.
- ✓ The status LEDs light up green after successful initialization. The product is ready for operation.
5. Install the device description file.
6. Select the product from the device catalog and add it to a project.
- ✓ A connection to the product is established via the communication interface. The connection must be activated for data transmission (**online**).

7.8 Connect+

Connect+ can be used optionally for teach-in settings and other parameter settings. To program the product with Connect+, a Connect+ adapter (CPA) and the Connect software are required. These are available as accessories.

8 Maintenance

8.1 Maintenance plan

During operation, the device works maintenance-free.

Table 6: Maintenance plan

Maintenance work	Interval	To be carried out by
Check device and connecting cables for damage at regular intervals.	Depends on ambient conditions and climate.	Specialist
Clean housing.	Depends on ambient conditions and climate.	Specialist
Check the screw connections and plug connectors.	Depends on the place of use, ambient conditions or operating requirements. Recommended: At least every 6 months.	Specialist

8.2 Cleaning



NOTICE

Equipment damage due to improper cleaning.

Improper cleaning may result in equipment damage.

- Only use recommended cleaning agents and tools.
 - Never use sharp objects for cleaning.
-
- ▶ Carefully clean the adjoining faces with water at regular intervals.

9 Troubleshooting

9.1 General faults

Possible faults and corrective actions are described in the table below for troubleshooting. In the case of faults that cannot be rectified using the description below, please contact the SICK Service department. To find your agency, see the final page of this document.



NOTE

To help us to resolve the matter quickly, please note down the details on the type label.

Table 7: Troubleshooting Q&A

Question / status	Response / remedial actions
Distance measurement is not possible.	Ensure that the object is within the measuring range.

9.2 Repairs

Repair work on the device may only be performed by qualified and authorized personnel from SICK AG. Interruptions or modifications to the device by the customer will invalidate any warranty claims against SICK AG.

9.3 Returns

- ▶ Only send in devices after consulting with SICK Service.
- ▶ The device must be sent in the original packaging or an equivalent padded packaging.



NOTE

To enable efficient processing and allow us to determine the cause quickly, please include the following when making a return:

- Details of the contact person
- Description of the application
- Description of the fault that occurred

9.4 Disposal

If a device can no longer be used, dispose of it in an environmentally friendly manner in accordance with the applicable country-specific waste disposal regulations. Do not dispose of the product along with household waste.



NOTICE

Danger to the environment due to improper disposal of the device.

Disposing of devices improperly may cause damage to the environment.

Therefore, observe the following information:

- Always observe the national regulations on environmental protection.
- Separate the recyclable materials by type and place them in recycling containers.

10 Technical data



NOTE

The relevant online product page for your product, including technical data, dimensional drawing, and connection diagrams, can be downloaded, saved, and printed from the Internet.

The page can be accessed via the **SICK Product ID: pid.sick.com/{P/N}/{S/N}**

{P/N} corresponds to the part number of the product, see type label.

{S/N} corresponds to the serial number of the product, see type label (if indicated).

Please note: This documentation may contain further technical data.

10.1 Mechanics/Electronics

Supply voltage V_S ¹⁾	Products with digital output DC 10 V ... 30 V Products with analog output Voltage output: <ul style="list-style-type: none"> DC 15 V ... 30 V Current output: <ul style="list-style-type: none"> DC 10 V ... 30 V at $R_L \leq 100 \Omega$ DC 20 V ... 30 V at $R_L > 100 \Omega$
Power consumption	$\leq 1.2 \text{ W}^{2)}$
Power-up time	< 300 ms
Design	Cylindrical
Housing material	Plastic (PBT) Ultrasonic converter: Polyurethane foam, epoxy resin with glass content
Threaded size	M18 x 1
Connection type	Male connector, M12, 4-pin
Display	2 LEDs
Weight	Straight: 25 g Angled: 30 g
Sending axis	UM18 – xxxxxxxx1: Straight UM18 – xxxxxxxx2: Angled
Dimensions	Straight: 18 mm x 18 mm x 52.7 mm ³⁾ Angled: 18 mm x 18 mm x 68.7 mm ³⁾
Enclosure rating	IP65 / IP67 (IEC 60529) ⁴⁾
Protection class	III
Max. tightening torque for fixing nuts	1 Nm

¹⁾ Limit values, reverse-polarity protected. Operation in short-circuit protected network: max. 8 A, class 2.

²⁾ Without load

³⁾ Deviations possible, see "Dimensional drawings", page 26.

⁴⁾ Prerequisites:

- The cables plugged into the electrical connections must be screwed tight. Unused electrical connections are sealed off with a protective cap.

10.2 Dimensional drawings

UM18-2xxx1/5/6/7xx1

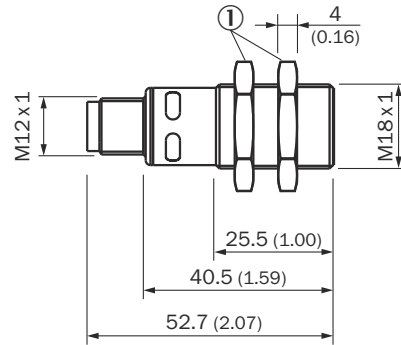

Figure 11: Structure and device dimensions, unit: mm (inch), decimal separator: period

① Fixing nuts, width 24 mm

UM18-2xxx1/5/6/7xx2

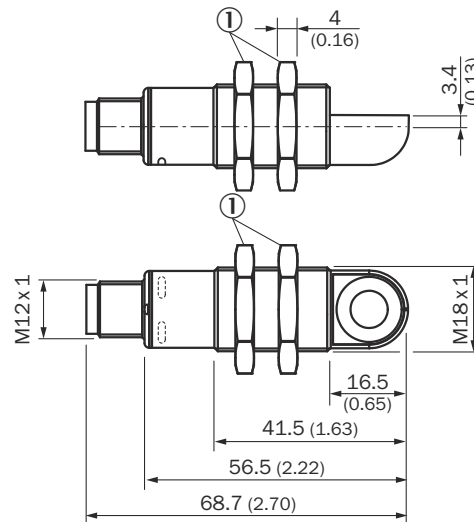

Figure 12: Structure and device dimensions, unit: mm (inch), decimal separator: period

① Fixing nuts, width 24 mm

10.3 Performance

Operating range, limiting range ¹⁾	UM18-217: 20 mm ... 150 mm, 250 mm UM18-211: 30 mm ... 250 mm, 350 mm UM18-212: 65 mm ... 350 mm, 600 mm UM18-218: 120 mm ... 1000 mm, 1300 mm
Measuring object	Natural objects
Resolution	≥ 0.2 mm
Repeatability	± 0.15% ²⁾
Accuracy	± 0.17 %/K ³⁾
Temperature compensation	No

Output time	UM18-217: 8 ms UM18-211: 8 ms UM18-212: 16 ms UM18-218: 20 ms
Response time ⁵⁾	UM18-217: 32 ms UM18-211: 32 ms UM18-212: 64 ms UM18-218: 80 ms
Switching frequency ⁶⁾	UM18-217: 25 Hz UM18-211: 25 Hz UM18-212: 12 Hz UM18-218: 10 Hz
Hysteresis ^{6) 7)}	UM18-217: 2 mm UM18-211: 3 mm UM18-212: 5 mm UM18-218: 20 mm
Ultrasonic frequency (typical)	UM18-217: 380 kHz UM18-211: 320 kHz UM18-212: 400 kHz UM18-218: 200 kHz
Additional function	Product with digital output <ul style="list-style-type: none"> Adjustable switching point modes Teachable digital output Invertible digital output
	Product with analog output <ul style="list-style-type: none"> Teachable analog output Invertible analog output
	All products <ul style="list-style-type: none"> Reset to factory settings

- 1) Distance measurement is not possible below the operating range of the product.
- 2) Relative to the current measured value, minimum value \geq resolution.
- 3) Relative to the current measured value.
- 5) Products with analog output: Subsequent smoothing of the analog output may increase the response time by up to 200 % in some applications.
- 6) Valid for products with digital output.
- 7) Adjustable via SOPAS ET, Connect+ or IO-Link.

10.4 Interfaces

IO-Link¹⁾	IO-Link 1.1 Function: Process data, parameterization, diagnostics, data storage
Digital output	UM18-2xxx1xxx: 1 PNP digital output UM18-2xxx5xxx: 1 PNP digital output
Analog output	UM18-2xxx6xxx: 1 analog current output, current: 4 mA ... 20 mA, RL \leq 500 Ω , resolution: 12 bit UM18-2xxx7xxx: 1 analog voltage output, voltage: 0 V ... 10 V, RL \geq 100 k Ω , resolution: 12 bit

- 1) Valid for products with digital output.

10.5 Ambient data

Ambient operating temperature	-25 °C ... +70 °C ¹⁾
--------------------------------------	---------------------------------

Storage temperature	-40 °C ... +85 °C
----------------------------	-------------------

1) To prevent condensation, avoid exposing the product to rapid changes in temperature.

10.6 Detection ranges

UM18-217xxxxx

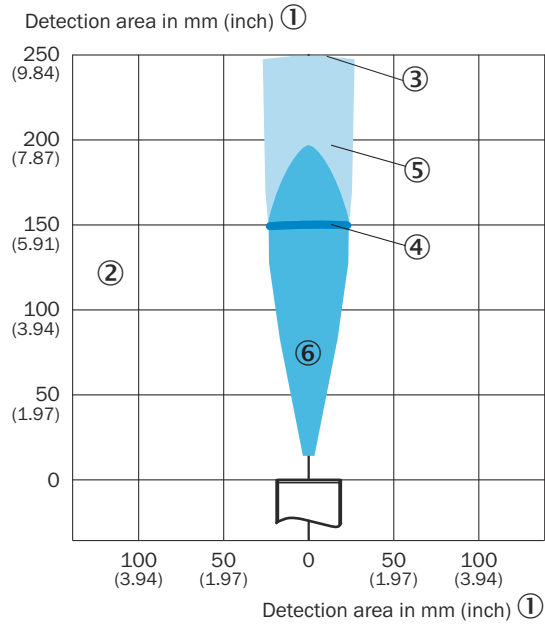

- ① Detection range in mm (inch)
- ② Detection range dependent on reflection properties, size, and alignment of the object
- ③ Limiting range
- ④ Operating range
- ⑤ Example object: aligned plate 500 mm x 500 mm
- ⑥ Example object: Cylindrical bar with diameter of 10 mm

UM18-211xxxxx

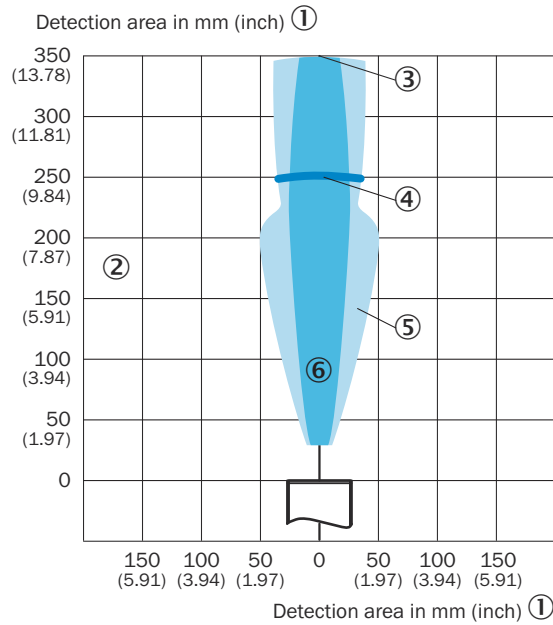

Figure 13: Um18-211xxxxx detection range

- ① Detection range in mm (inch)
- ② Detection range dependent on reflection properties, size, and alignment of the object
- ③ Limiting range
- ④ Operating range
- ⑤ Example object: Aligned plate 500 mm x 500 mm
- ⑥ Example object: Cylindrical bar with diameter of 10 mm

UM18-212xxxxx

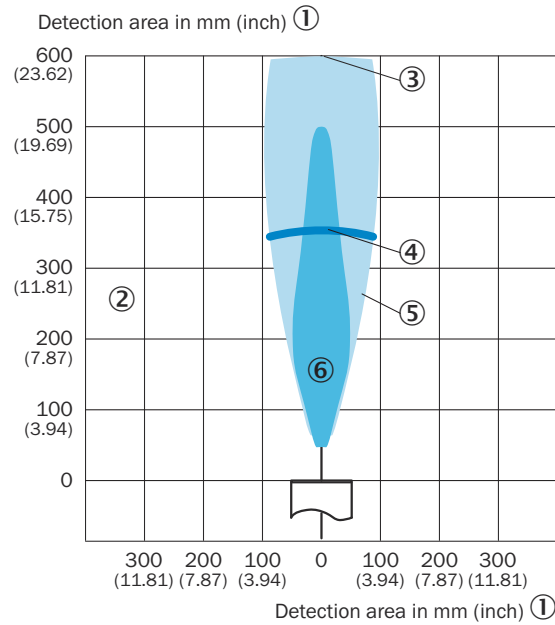

Figure 14: Um18-212xxxxx detection range

- ① Detection range in mm (inch)
- ② Detection range dependent on reflection properties, size, and alignment of the object
- ③ Limiting range
- ④ Operating range
- ⑤ Example object: Aligned plate 500 mm x 500 mm
- ⑥ Example object: Cylindrical bar with diameter of 27 mm

UM18-218xxxxxx

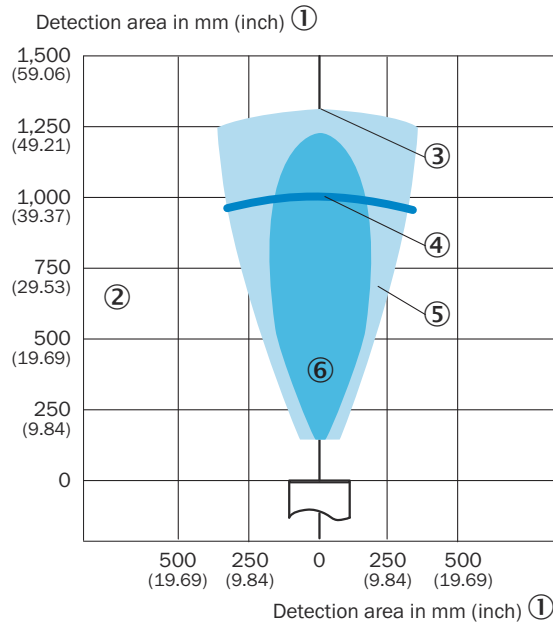

Figure 15: Um18-218xxxxxx detection range

- ① Detection range in mm (inch)
- ② Detection range dependent on reflection properties, size, and alignment of the object
- ③ Limiting range
- ④ Operating range
- ⑤ Example object: Aligned plate 500 mm x 500 mm
- ⑥ Example object: Cylindrical bar with diameter of 27 mm

11 Accessories

**NOTE**

On the product page you will find accessories and, if applicable, related installation information for your product.

The page can be accessed via the **SICK Product ID: pid.sick.com/{P/N}/{S/N}**

{P/N} corresponds to the part number of the product, see type label.

{S/N} corresponds to the serial number of the product, see type label (if indicated).

12 Annex

12.1 Declarations of conformity and certificates

You can download declarations of conformity and certificates via the product page.

The page can be accessed via the **SICK Product ID: pid.sick.com/{P/N}/{S/N}**

{P/N} corresponds to the part number of the product, see type label.

{S/N} corresponds to the serial number of the product, see type label (if indicated).

12.2 Licenses

SICK uses open source software which is published by the rights holders under a free license. Among others, the following license types are used: GNU General Public License (GPL version 2, GPL version 3), GNU Lesser General Public License (LGPL), MIT license, zlib license and licenses derived from the BSD license.

This program is provided for general use without warranty of any kind. This warranty disclaimer also extends to the implicit assurance of marketability or suitability of the program for a particular purpose.

More details can be found in the GNU General Public License.

For license texts see www.sick.com/licensetexts.

Printed copies of the license texts are also available on request.

Australia

Phone +61 (3) 9457 0600
1800 33 48 02 – tollfree
E-Mail sales@sick.com.au

Austria

Phone +43 (0) 2236 62288-0
E-Mail office@sick.at

Belgium/Luxembourg

Phone +32 (0) 2 466 55 66
E-Mail info@sick.be

Brazil

Phone +55 11 3215-4900
E-Mail comercial@sick.com.br

Canada

Phone +1 905.771.1444
E-Mail cs.canada@sick.com

Czech Republic

Phone +420 234 719 500
E-Mail sick@sick.cz

Chile

Phone +56 (2) 2274 7430
E-Mail chile@sick.com

China

Phone +86 20 2882 3600
E-Mail info.china@sick.net.cn

Denmark

Phone +45 45 82 64 00
E-Mail sick@sick.dk

Finland

Phone +358-9-25 15 800
E-Mail sick@sick.fi

France

Phone +33 1 64 62 35 00
E-Mail info@sick.fr

Germany

Phone +49 (0) 2 11 53 010
E-Mail info@sick.de

Greece

Phone +30 210 6825100
E-Mail office@sick.com.gr

Hong Kong

Phone +852 2153 6300
E-Mail ghk@sick.com.hk

Hungary

Phone +36 1 371 2680
E-Mail erteakesites@sick.hu

India

Phone +91-22-6119 8900
E-Mail info@sick-india.com

Israel

Phone +972 97110 11
E-Mail info@sick-sensors.com

Italy

Phone +39 02 27 43 41
E-Mail info@sick.it

Japan

Phone +81 3 5309 2112
E-Mail support@sick.jp

Malaysia

Phone +603-8080 7425
E-Mail enquiry.my@sick.com

Mexico

Phone +52 (472) 748 9451
E-Mail mexico@sick.com

Netherlands

Phone +31 (0) 30 204 40 00
E-Mail info@sick.nl

New Zealand

Phone +64 9 415 0459
0800 222 278 – tollfree
E-Mail sales@sick.co.nz

Norway

Phone +47 67 81 50 00
E-Mail sick@sick.no

Poland

Phone +48 22 539 41 00
E-Mail info@sick.pl

Romania

Phone +40 356-17 11 20
E-Mail office@sick.ro

Singapore

Phone +65 6744 3732
E-Mail sales.gsg@sick.com

Slovakia

Phone +421 482 901 201
E-Mail mail@sick-sk.sk

Slovenia

Phone +386 591 78849
E-Mail office@sick.si

South Africa

Phone +27 10 060 0550
E-Mail info@sickautomation.co.za

South Korea

Phone +82 2 786 6321/4
E-Mail infokorea@sick.com

Spain

Phone +34 93 480 31 00
E-Mail info@sick.es

Sweden

Phone +46 10 110 10 00
E-Mail info@sick.se

Switzerland

Phone +41 41 619 29 39
E-Mail contact@sick.ch

Taiwan

Phone +886-2-2375-6288
E-Mail sales@sick.com.tw

Thailand

Phone +66 2 645 0009
E-Mail marcom.th@sick.com

Turkey

Phone +90 (216) 528 50 00
E-Mail info@sick.com.tr

United Arab Emirates

Phone +971 (0) 4 88 65 878
E-Mail contact@sick.ae

United Kingdom

Phone +44 (0)17278 31121
E-Mail info@sick.co.uk

USA

Phone +1 800.325.7425
E-Mail info@sick.com

Vietnam

Phone +65 6744 3732
E-Mail sales.gsg@sick.com

Detailed addresses and further locations at www.sick.com