



SBO-02G12-SM

SICK
Sensor Intelligence.



Illustration may differ

Ordering information

Type	Part no.
SBO-02G12-SM	6029305

Other models and accessories → www.sick.com/

Detailed technical data

Technical specifications

Accessory family	T-junctions
Connection type head A	Female connector, M12, 5-pin, A-coded
Connection type head B	Female connector, M12, 5-pin, A-coded
Connection type head C	Male connector, M12, 5-pin, A-coded
Housing material	TPU
Connector material head A	TPU
Connector material head B	TPU
Connector material head C	TPU
Housing color	Black
Locking nut material	Nickel-plated brass
Shielding, head	Unshielded
Reference voltage	≤ 60 V DC
Current loading	4 A
Note	Male connector M12, 5-pin, straight, A-coded to 2 x female connector M12, 5-pin, straight, A-coded
Ambient operating temperature	-30 °C ... +90 °C
Enclosure rating	IP67 ¹⁾
Ambient operating temperature	Head -30 °C ... +90 °C

¹⁾ Only in fully locked position with its plugs.

Dimensional drawing (Dimensions in mm (inch))

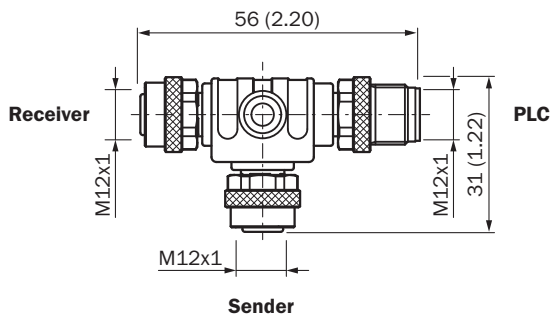

Connection type

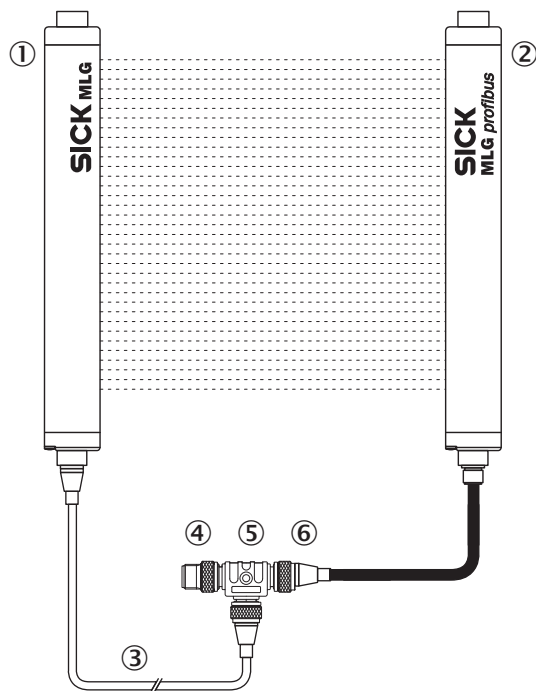

- ① MLG sender
- ② MLG receiver
- ③ Connection cable
- ④ Supply Q1
- ⑤ T-piece
- ⑥ MLG connection

Anschlusschema

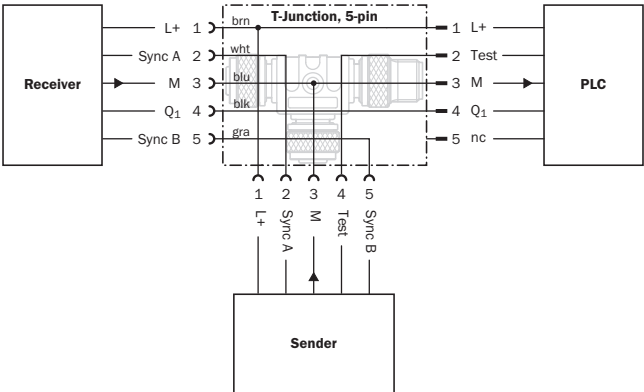

SICK AT A GLANCE

SICK is one of the leading manufacturers of intelligent sensors and sensor solutions for industrial applications. A unique range of products and services creates the perfect basis for controlling processes securely and efficiently, protecting individuals from accidents and preventing damage to the environment.

We have extensive experience in a wide range of industries and understand their processes and requirements. With intelligent sensors, we can deliver exactly what our customers need. In application centers in Europe, Asia and North America, system solutions are tested and optimized in accordance with customer specifications. All this makes us a reliable supplier and development partner.

Comprehensive services complete our offering: SICK LifeTime Services provide support throughout the machine life cycle and ensure safety and productivity.

For us, that is “Sensor Intelligence.”

WORLDWIDE PRESENCE:

Contacts and other locations –www.sick.com