

# UM12

Ultrasonic sensor

**SICK**  
Sensor Intelligence.

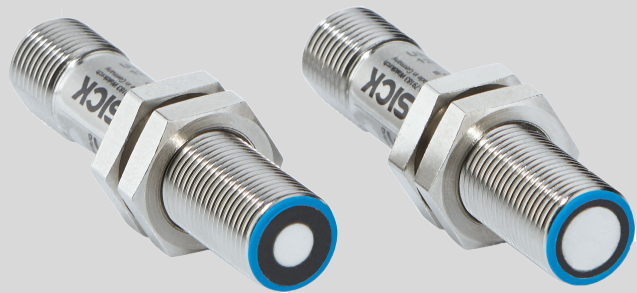

## Described product

UM12

## Manufacturer

SICK AG  
Erwin-Sick-Str. 1  
79183 Waldkirch  
Germany

## Legal information

This work is protected by copyright. Any rights derived from the copyright shall be reserved for SICK AG. Reproduction of this document or parts of this document is only permissible within the limits of the legal determination of Copyright Law. Any modification, abridgment or translation of this document is prohibited without the express written permission of SICK AG.

The trademarks stated in this document are the property of their respective owner.

© SICK AG. All rights reserved.

## Original document

This document is an original document of SICK AG.

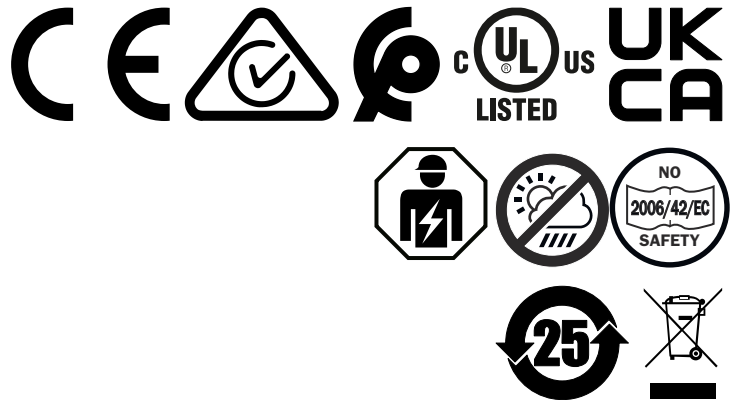

## Contents

<b>1</b>	<b>About this document.....</b>	<b>5</b>
1.1	Information on the operating instructions.....	5
1.2	Symbols and document conventions.....	5
1.3	Further information.....	5
<b>2</b>	<b>Safety information.....</b>	<b>7</b>
2.1	Intended use.....	7
2.2	Improper use.....	7
2.3	Cybersecurity.....	7
2.4	Limitation of liability.....	7
2.5	Modifications and conversions.....	8
2.6	Qualification of personnel.....	8
2.7	Operational safety and specific hazards.....	8
2.8	UL conformity.....	9
<b>3</b>	<b>Product description.....</b>	<b>10</b>
3.1	Product identification via the SICK product ID.....	10
3.2	Scope of delivery.....	10
3.3	Type code.....	10
3.4	Product overview.....	11
<b>4</b>	<b>Transport and storage.....</b>	<b>12</b>
4.1	Transport.....	12
4.2	Unpacking.....	12
4.3	Transport inspection.....	12
4.4	Storage.....	12
<b>5</b>	<b>Mounting.....</b>	<b>13</b>
5.1	Mounting instructions.....	13
5.2	Mounting distances.....	13
5.3	Aligning the device.....	13
5.4	Aligning device with alignment aid.....	13
<b>6</b>	<b>Electrical installation.....</b>	<b>15</b>
6.1	Wiring instructions.....	15
6.2	Prerequisites for safe operation of the device.....	15
6.3	Pinouts.....	17
<b>7</b>	<b>Operation.....</b>	<b>20</b>
7.1	Status indicators.....	20
7.2	Digital output teach-in.....	20
7.2.1	Factory settings of the digital output.....	20
7.2.2	Teaching in switching point (Single Point Mode).....	20
7.2.3	Teaching in switching window (Window Mode).....	21
7.2.4	Teaching in background (Window Mode $\pm$ 8%).....	21

7.2.5	Adjusting the N/C contact and N/O contact.....	22
7.3	Analog output teach-in.....	22
7.3.1	Factory settings of the analog output.....	22
7.3.2	Scaling the analog output.....	22
7.3.3	Adjusting the rising or falling output characteristic.....	23
7.4	Resetting the product to factory settings.....	23
7.5	Activating and deactivating teach-in and synchronization.....	23
7.6	IO-Link.....	24
7.7	Establishing a connection to SOPAS ET.....	24
<b>8</b>	<b>Maintenance.....</b>	<b>25</b>
8.1	Maintenance schedule.....	25
8.2	Cleaning.....	25
<b>9</b>	<b>Troubleshooting.....</b>	<b>26</b>
9.1	Repair.....	26
9.2	Return.....	26
9.3	Disposal.....	26
<b>10</b>	<b>Technical data.....</b>	<b>27</b>
10.1	Mechanics/Electronics.....	27
10.2	Performance.....	27
10.3	Interfaces.....	28
10.4	Ambient data.....	28
10.5	Temperature compensation.....	28
10.6	Detection ranges.....	29
10.7	Dimensional drawing.....	30
<b>11</b>	<b>Accessories.....</b>	<b>32</b>
<b>12</b>	<b>Annex.....</b>	<b>33</b>
12.1	Declarations of conformity and certificates.....	33
12.2	Licenses.....	33

# 1 About this document

## 1.1 Information on the operating instructions

Read these operating instructions carefully before starting any work in order to familiarize yourself with the product and its functions.

The operating instructions are an integral part of the product and should remain accessible to the personnel at all times. When handing this product over to a third party, include these operating instructions.

These operating instructions do not provide information on the handling and safe operation of the machine or system in which the product is integrated. Information on this can be found in the operating instructions for the machine or system.

## 1.2 Symbols and document conventions

### Warnings and other notes



#### DANGER

Indicates a situation presenting imminent danger, which will lead to death or serious injuries if not prevented.



#### WARNING

Indicates a situation presenting possible danger, which may lead to death or serious injuries if not prevented.



#### CAUTION

Indicates a situation presenting possible danger, which may lead to moderate or minor injuries if not prevented.



#### NOTICE

Indicates a situation presenting possible danger, which may lead to property damage if not prevented.



#### NOTE

Highlights useful tips and recommendations as well as information for efficient and trouble-free operation.

### Instructions to action

- ▶ The arrow denotes instructions to action.
- 1. The sequence of instructions is numbered.
- 2. Follow the order in which the numbered instructions are given.
- ✓ The tick denotes the results of an action.

## 1.3 Further information

You can find the product page with further information via the SICK Product ID: [pid.sick.com/{P/N}/{S/N}](https://pid.sick.com/{P/N}/{S/N}) (see "Product identification via the SICK product ID", page 10).

The following information is available depending on the product:

- This document in all available language versions
- Data sheets

## 1 ABOUT THIS DOCUMENT

---

- Other publications
- CAD files and dimensional drawings
- Certificates (e.g., declaration of conformity)
- Software
- Accessories

## 2 Safety information

### 2.1 Intended use

The UM12 ultrasonic sensor is used for non-contact detection and distance measurement. Distance measurement is not possible below the operating range of the device.

SICK AG assumes no liability for losses or damage arising from the use of the product, either directly or indirectly. This applies in particular to use of the product that does not conform to its intended purpose and is not described in this documentation.

### 2.2 Improper use

Any use outside of the stated areas, in particular use outside of the technical specifications and the requirements for intended use, will be deemed to be incorrect use.

- The device does not constitute a safety component in accordance with the respective applicable safety standards for machines.
- The device must not be used in explosion-hazardous or corrosive areas or under extreme ambient conditions.
- Any use of accessories not specifically approved by SICK AG is at your own risk.



#### WARNING

##### Danger due to improper use!

Any improper use can result in dangerous situations.

Therefore, observe the following information:

- Product should be used only in accordance with its intended use.
- All information in the documentation must be strictly observed.
- Shut down the product immediately in case of damage.

### 2.3 Cybersecurity

#### Overview

To protect against cybersecurity threats, it is necessary to continuously monitor and maintain a comprehensive cybersecurity concept. A suitable concept consists of organizational, technical, procedural, electronic, and physical levels of defense and considers suitable measures for different types of risks. The measures implemented in this product can only support protection against cybersecurity threats if the product is used as part of such a concept.

You will find further information at [www.sick.com/psirt](http://www.sick.com/psirt), e.g.:

- General information on cybersecurity
- Contact option for reporting vulnerabilities
- Information on known vulnerabilities (security advisories)

### 2.4 Limitation of liability

Relevant standards and regulations, the latest technological developments, and our many years of knowledge and experience have all been taken into account when compiling the information and notes contained in these operating instructions. The manufacturer accepts no liability for damage caused by:

- Non-compliance with product documentation (e.g. operating instructions)
- Improper use
- Use of untrained staff.
- Unauthorized conversions or repair

- Technical modifications
- Use of unauthorized spare parts, wear and tear parts, and accessories

### 2.5 Modifications and conversions

---



#### NOTICE

Modifications and conversions to the device may result in unforeseeable dangers.

---

Interrupting or modifying the device or SICK software will invalidate any warranty claims against SICK AG. This applies in particular to opening the housing, even as part of mounting and electrical installation.

### 2.6 Qualification of personnel

Any work on the product may only be carried out by personnel qualified and authorized to do so.

Qualified personnel are able to perform tasks assigned to them and can independently recognize and avoid any potential hazards. This requires, for example:

- technical training
- experience
- knowledge of the applicable regulations and standards

### 2.7 Operational safety and specific hazards

Please observe the safety notes and the warnings listed here and in other sections of this product documentation to reduce the possibility of risks to health and avoid dangerous situations.

---



#### WARNING

##### Electrical voltage!

Electrical voltage can cause severe injury or death.

- Work on electrical systems must only be performed by qualified electricians.
  - The power supply must be disconnected when attaching and detaching electrical connections.
  - The product must only be connected to a voltage supply as set out in the requirements in the operating instructions.
  - National and regional regulations must be complied with.
  - Safety requirements relating to work on electrical systems must be complied with.
- 



#### WARNING

##### Risk of injury and damage caused by potential equalization currents!

Improper grounding can lead to dangerous equipotential bonding currents, which may in turn lead to dangerous voltages on metallic surfaces, such as the housing. Electrical voltage can cause severe injury or death.

- Work on electrical systems must only be performed by qualified electricians.
  - Follow the notes in the operating instructions.
  - Install the grounding for the product and the system in accordance with national and regional regulations.
-

## 2.8 UL conformity

The UL certification is type-dependent. Any existing UL certification can be found on the type label.



NFPA79 applications only. Adapters including connecting cables are available.

More information can be found on the product page:

The product page can be accessed via the **SICK Product ID: [pid.sick.com/{P/N}/{S/N}](https://pid.sick.com/{P/N}/{S/N})**

**{P/N}** corresponds to the part number of the product, see type label.

**{S/N}** corresponds to the serial number of the product, see type label (if indicated).

### 3 Product description

#### 3.1 Product identification via the SICK product ID

##### SICK product ID

The SICK product ID uniquely identifies the product. It also serves as the address of the web page with information on the product.

The SICK product ID comprises the host name pid.sick.com, the part number (P/N), and the serial number (S/N), each separated by a forward slash.

For many products, the SICK product ID is displayed as text and QR code on the type label and/or on the packaging.



Figure 1: SICK product ID

#### 3.2 Scope of delivery

Table 1: Scope of delivery

No. of units	Component	Note
1	Product in the type ordered	-
1	Printed safety notes, multilingual	Brief information and general safety notes

The actual scope of delivery may differ for special designs, additional orders or due to the latest technical changes.

#### 3.3 Type code

##### Type code structure

UM12 – a b c d e f g

Table 2: Type code

Position	Description	Characteristic
a	Generation	1: 1. generation
b	Principle of operation	1: Button operation
c	Detection range, mounting distance (UD)	7: 20 mm ... 150 mm 9: 40 mm ... 240 mm
d	Connectivity	2: Male connector M12, 4-pin
e	Housing version	2: Nickel-plated brass
f	Output function	1: 1 PNP 5: 1 NPN 6: Analog, current interface 7: Analog, voltage interface B: 1 push-pull: PNP/NPN with IO-Link 1.1
g	Alignment	1: Straight

### 3.4 Product overview

#### Product overview

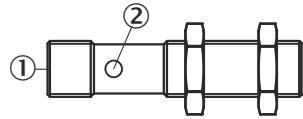

Figure 2: Device view

- ① Connection
- ② Display (2 status LEDs)

#### Further topics

- [Dimensional drawing](#)

### 4 Transport and storage

#### 4.1 Transport

**NOTICE****Damage due to improper transport!**

- The product must be packaged with protection against shock and damp.
  - Recommendation: Use the original packaging.
  - Note the symbols on the packaging.
  - Do not remove packaging until immediately before you start mounting.
- 

#### 4.2 Unpacking

- To protect the device against condensation, allow it to equilibrate with the ambient temperature before unpacking if necessary.
- Handle the device with care and protect it from mechanical damage.

#### 4.3 Transport inspection

Immediately upon receipt in incoming goods, check the delivery for completeness and for any damage that may have occurred in transit. In the case of transit damage that is visible externally, proceed as follows:

- Do not accept the delivery or only do so conditionally.
  - Note the extent of damage on the transport documents or on the transport company's delivery note.
  - File a complaint.
- 

**NOTE**

Complaints regarding defects should be filed as soon as these are detected. Damage claims are only valid before the applicable complaint deadlines.

---

#### 4.4 Storage

- Do not store outdoors.
- Store in a place protected from moisture and dust.
- Recommendation: Use the original packaging.
- Do not expose to any aggressive substances.
- Protect from sunlight.
- Avoid mechanical shocks.
- Storage temperature: [see "Technical data", page 27](#).
- For storage periods of longer than 3 months, check the general condition of all components and packaging on a regular basis.

## 5 Mounting

### 5.1 Mounting instructions

- Observe the technical data.
- To prevent condensation, avoid exposing the device to rapid changes in temperature.
- The mounting site has to be designed for the weight of the device.
- When using multiple devices, observe the mounting distance, see "Mounting distances", page 13.

### 5.2 Mounting distances

Device type	Parallel	Opposite
UM12-117x	> 250 mm	> 1300 mm
UM12-119x	> 250 mm	> 1400 mm

### 5.3 Aligning the device

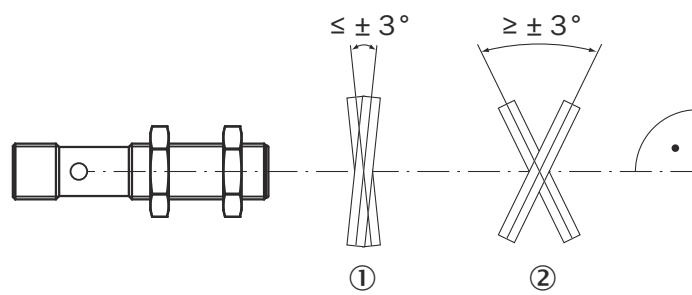

Figure 3: Aligning the device for smooth and rough surfaces

- ① Smooth surface: Angle  $\leq 90^\circ \pm 3^\circ$  between the sensor axis and object surface
- ② Rough surface: Angle  $\geq 90^\circ \pm 3^\circ$  between the sensor axis and object surface

### 5.4 Aligning device with alignment aid

#### Overview

The alignment aid can be used to align the device with the object during mounting. Valid for devices with IO-Link (UM12-xxxxxBx).

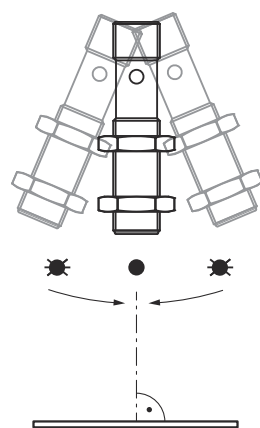

● = lit up; ● = flashing.

### Procedure

1. Loosely fasten the device at the installation location so that the device remains movable.
2. To start the alignment aid, briefly apply **L+** at **Teach-in**.
  - ✓ Green LED flashes. The faster the LED flashes, the stronger the received signal.
3. Align the device at the object at different angles for up to 10 seconds so that the device can determine the maximum signal level.
  - ✓ Green LED flashes or permanently lights up green.
4. Align the device so that the green LED permanently lights up green.
  - ✓ Green LED permanently lights up green.
5. Fasten the device in this position.
6. To end the alignment aid, briefly apply **L+** at **Teach-in** or wait 120 seconds.
  - ✓ Orange LED flashes twice.
  - ✓ The device switches back to normal operation.

## 6 Electrical installation

### 6.1 Wiring instructions



#### NOTE

Pre-assembled cables can be found on the product page.

It can be accessed via the **SICK Product ID: [pid.sick.com/{P/N}/{S/N}](https://pid.sick.com/{P/N}/{S/N})**

{P/N} corresponds to the part number of the product, see type label.

{S/N} corresponds to the serial number of the product, see type label (if specified).



#### NOTICE

##### Faults during operation and defects in the device or the system

Incorrect wiring may result in operational faults and defects.

- Follow the wiring notes precisely.

The enclosure rating stated in the technical data is achieved only with a screwed plug connector or protective cap. Connect the connecting cables in a de-energized state.

Do not switch on the supply voltage until installation is complete and all connecting cables are connected to the device and controller.

The supply voltage must be as specified in the technical data, see "Technical data", page 27.

When commissioning, protect the device from moisture and contamination.

### 6.2 Prerequisites for safe operation of the device



#### WARNING

##### Risk of injury and damage caused by electrical current!

As a result of equipotential bonding currents between the device and other grounded devices in the system, faulty grounding of the device can give rise to the following dangers and faults:

- Dangerous voltages are applied to the metal housings.
- Devices will behave incorrectly or be destroyed.
- Cable shielding will be damaged by overheating and cause cable fires.

##### Remedial measures

- Only skilled electricians should be permitted to carry out work on the electrical system.
- If the cable insulation is damaged, disconnect the voltage supply immediately and have the damage repaired.
- Ensure that the ground potential is the same at all grounding points.
- Where local conditions do not meet the requirements for a safe earthing method, take appropriate measures. For example, ensure low-impedance and current-carrying equipotential bonding.

The device is connected to the peripheral devices (any local trigger sensor(s), system controller) via shielded cables. The cable shield – for the data cable, for example – rests against the metal housing of the device.

The device can be grounded through the cable shield or through a blind tapped hole in the housing, for example.

If the peripheral devices have metal housings and the cable shields are also in contact with their housings, it is assumed that all devices involved in the installation have the **same ground potential**.

This is achieved by complying with the following conditions:

- Mounting the devices on conductive metal surfaces.
- Correctly grounding the devices and metal surfaces in the system
- If necessary: Low-impedance and current-carrying equipotential bonding between areas with different ground potentials

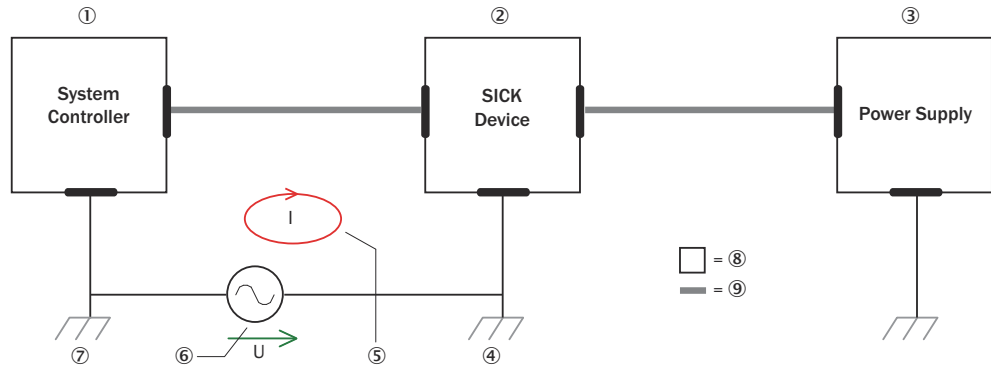

Figure 4: Example: Occurrence of equipotential bonding currents in the system configuration

- ① System controller
- ② Device
- ③ Voltage supply
- ④ Grounding point 2
- ⑤ Closed current loop with equalizing currents via cable shield
- ⑥ Ground potential difference
- ⑦ Grounding point 1
- ⑧ Metal housing
- ⑨ Shielded electrical cable

If these conditions are not fulfilled, equipotential bonding currents can flow along the cable shielding between the devices due to differing ground potentials and cause the hazards specified. This is, for example, possible in cases where there are devices within a widely distributed system covering several buildings.

**Remedial measures**

The most common solution to prevent equipotential bonding currents on cable shields is to ensure low-impedance and current-carrying equipotential bonding. If this equipotential bonding is not possible, the following solution approaches serve as a suggestion.



**NOTICE**

We expressly advise against opening up the cable shields. This would mean that the EMC limit values can no longer be complied with and that the safe operation of the device data interfaces can no longer be guaranteed.

**Measures for widely distributed system installations**

On widely distributed system installations with correspondingly large potential differences, the setting up of local islands and connecting them using commercially available **electro-optical signal isolators** is recommended. This measure achieves a high degree of resistance to electromagnetic interference.

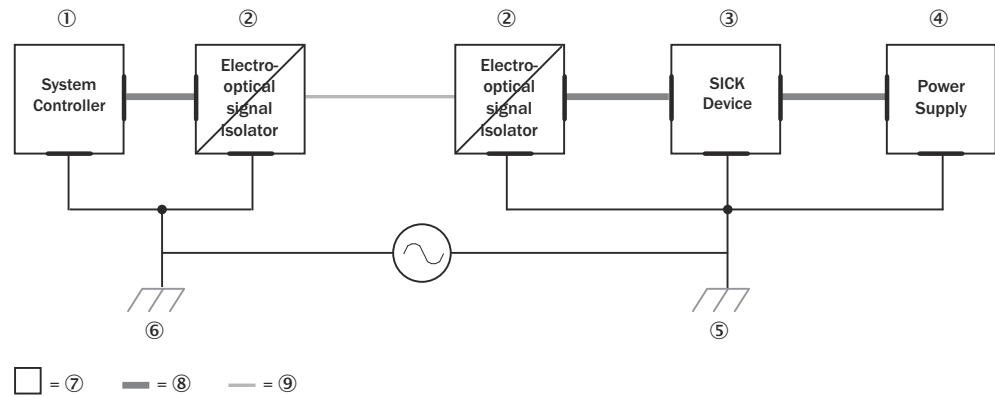

Figure 5: Example: Prevention of equipotential bonding currents in the system configuration by the use of electro-optical signal isolators

- ① System controller
- ② Electro-optical signal isolator
- ③ Device
- ④ Voltage supply
- ⑤ Grounding point 2
- ⑥ Grounding point 1
- ⑦ Metal housing
- ⑧ Shielded electrical cable
- ⑨ Optical fiber

The use of electro-optical signal isolators between the islands isolates the ground loop. Within the islands, a stable equipotential bonding prevents equalizing currents on the cable shields.

#### Measures for small system installations

For smaller installations with only slight potential differences, insulated mounting of the device and peripheral devices may be an adequate solution.

Even in the event of large differences in the ground potential, ground loops are effectively prevented. As a result, equalizing currents can no longer flow via the cable shields and metal housing.



#### NOTICE

The power supply for the device and the connected peripherals must then also ensure the required insulation.

Under certain circumstances, a touchable potential may arise between the insulated metal enclosures and the local earth potential.

## 6.3 Pinouts

### UM12-xxxxx1x, UM12-xxxxx5x

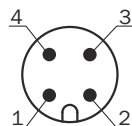

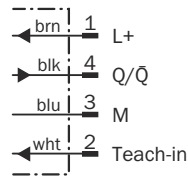

Figure 6: Male connector, M12, 4-pin

Table 3: Pin assignment for UM12-xxxxx1x, UM12-xxxxx5x

Contact	Signs	Wire color	Description
1	L+	Brown	Supply voltage, see "Mechanics/Electronics", page 27
2	Teach-in	White	Device teach-in
3	M	Blue	Supply voltage: 0 V
4	Q/Q̄	Black	Digital output / inverted digital output

**UM12-xxxxxBx**

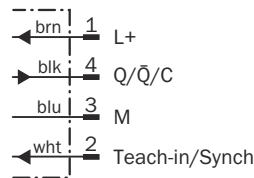
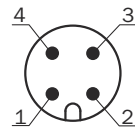

Figure 7: Male connector, M12, 4-pin

Table 4: Pin assignment for UM12-xxxxxBx

Contact	Signs	Wire color	Description
1	L+	Brown	Supply voltage, see "Mechanics/Electronics", page 27
2	Teach-in/Synch	White	Device teach-in/synchronization operation
3	M	Blue	Supply voltage: 0 V
4	Q/Q̄/C	Black	Digital input / inverted digital output / IO-Link

**UM12-xxxxx6x, UM12-xxxxx7x**

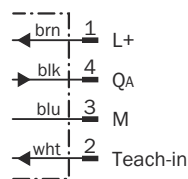
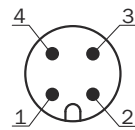

Figure 8: Male connector, M12, 4-pin

Table 5: Pin assignment for UM12-xxxxx6x, UM12-xxxxx7x

Contact	Signs	Wire color	Description
1	L+	Brown	Supply voltage, see " <a href="#">Mechanics/Electronics</a> ", page 27
2	Teach-in	White	Device teach-in
3	M	Blue	Supply voltage: 0 V
4	Q <sub>A</sub>	Black	Analog output

## 7 Operation

### 7.1 Status indicators

#### Overview

The display consists of two status LEDs behind an opening in the housing.

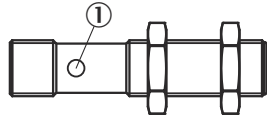

① Display (2 status LEDs)

#### Status LEDs

LED	Status (color)	Status
Status LED: Supply voltage active	● (Green)	Device ready
	● (green)	
Status LED: digital output or analog output	● (Orange)	Digital output: digital output active Analog output: object in scaling range
	☀ (Orange) Flashes quickly for 3 seconds.	<b>Teach-in:</b> <ul style="list-style-type: none"> <li>• No object detected</li> <li>• Object outside the detection range</li> <li>• First switching point within and second switching point outside the detection range <sup>1)</sup></li> <li>• Scaling &lt; 1 mm taught-in <sup>2)</sup></li> </ul> The existing switching points are retained.

● = Lights up; ● = Flashes; ○ = Does not light up.

<sup>1)</sup> Valid for the switching point modes Window Mode and Window Mode ± 8%.

<sup>2)</sup> Applies when teaching in the analog output.

### 7.2 Digital output teach-in

#### 7.2.1 Factory settings of the digital output

- N/O contact
- Switching point at maximum operating range

#### 7.2.2 Teaching in switching point (Single Point Mode)

##### Overview

When the object is located below the taught-in switching point, the digital output is active.

##### Procedure

Teaching in the switching point (distance to object as switching point)

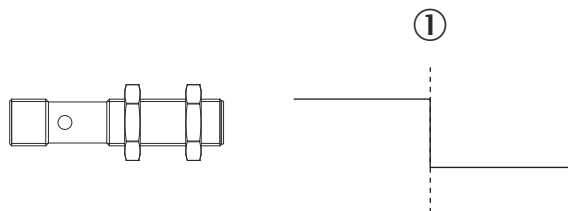

1. Position the object at ①.

2. Apply L+ at Teach-in for 3 seconds until both LEDs are flashing simultaneously.
  - ✓ Both LEDs flash alternately.
3. Apply L+ at Teach-in for 1 second.
  - ✓ The switching point is taught in. The device automatically switches to normal operation mode.

Teaching in the switching point + 8% (distance + 8% as switching point)

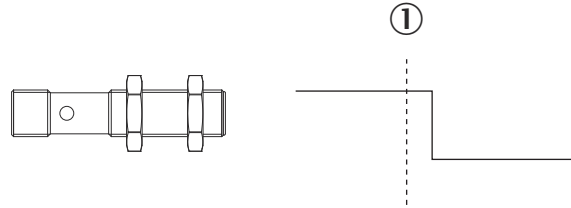

1. Position the object at ①.
2. Apply L+ at Teach-in for 3 seconds until both LEDs are flashing simultaneously.
  - ✓ Both LEDs flash alternately.
3. Apply L+ at Teach-in for 3 seconds until both LEDs are again flashing alternately.
  - ✓ The switching point is taught in. The device automatically switches to normal operation mode.

### 7.2.3 Teaching in switching window (Window Mode)

#### Overview

When the object is located within the taught-in switching window, the digital output is active.

#### Procedure

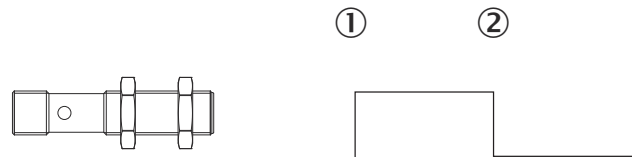

Figure 9: UM12-xxxxxBx

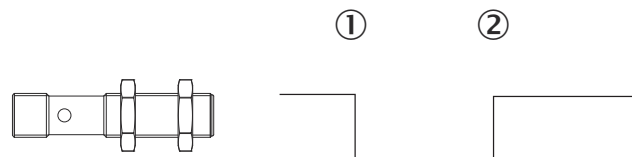

Figure 10: UM12-xxxxx1x, UM12-xxxxx5x

1. Position the object at ①.
2. Apply L+ at Teach-in for 3 seconds until both LEDs are flashing simultaneously.
  - ✓ Both LEDs flash alternately.
3. Position the object at ②.
4. Apply L+ at Teach-in for 1 second.
  - ✓ The switching points are taught-in. The device automatically switches to normal operation mode.

### 7.2.4 Teaching in background (Window Mode $\pm 8\%$ )

#### Overview

When the object is located either below the taught-in background - 8% or above the taught-in background + 8%, the digital output is active.

**Procedure**

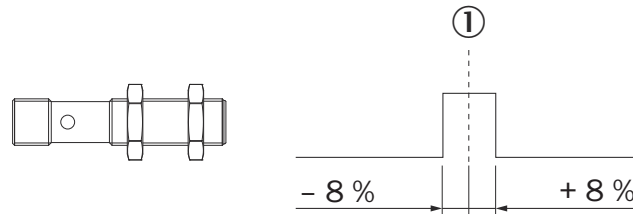

Figure 11: UM12-xxxxBx, UM12-xxxx1x, UM12-xxxx5x

1. Position the background at ①.
2. Apply L+ at Teach-in for 3 seconds until both LEDs are flashing simultaneously.
  - ✓ Both LEDs flash alternately.
3. Apply L+ at Teach-in for 10 seconds until both LEDs stop flashing.
  - ✓ The background is taught-in. The device automatically switches to normal operation mode.

**7.2.5 Adjusting the N/C contact and N/O contact**

**Procedure**

1. Apply L+ at Teach-in for 13 seconds until both LEDs flash alternately.
  - ✓ Green LED flashes.
  - ✓ N/O: Orange LED lights up.
  - ✓ N/C: Orange LED does not light up.
2. To change the setting, apply L+ at Teach-in for 1 second.
  - ✓ Orange LED changes its status.
3. Wait 10 seconds.
  - ✓ Green LED no longer flashes.
  - ✓ N/C and N/O are adjusted. The device automatically switches to normal operation mode.

**7.3 Analog output teach-in**

**7.3.1 Factory settings of the analog output**

- Rising output characteristic from minimum to maximum operating range

**7.3.2 Scaling the analog output**

**Overview**

To scale the analog output, teach in a close sensor and distant sensor scaling limit. If the distant sensor scaling limit is taught in first and then the close sensor scaling limit, the limits are reversed internally.

**Procedure**

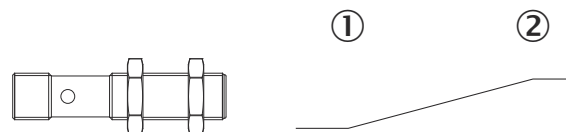

1. Position the object at ①.
2. Apply L+ at MF for 3 seconds until both LEDs are flashing simultaneously.
  - ✓ Both LEDs flash alternately.
3. Position the object at ②.

4. Apply L+ at MF for 1 second.
- ✓ The scaling is taught-in. The device automatically switches to normal operation mode.

### 7.3.3 Adjusting the rising or falling output characteristic

#### Procedure

1. Apply L+ at MF for 13 seconds until both LEDs flash alternately.
- ✓ Green LED flashes.
- ✓ Rising: Orange LED lights up.
- ✓ Falling: Orange LED does not light up.
2. To change the setting, apply L+ at MF for 1 second.
- ✓ Orange LED changes its status.
3. Wait 10 seconds.
- ✓ Green LED no longer flashes.
- ✓ The rising or falling output characteristic is set. The product automatically switches to normal operation mode.

## 7.4 Resetting the product to factory settings

#### Procedure

##### UM12-xxxxxBx

1. Switch off the supply voltage.
2. Apply M at Teach-in.
3. Switch on the supply voltage.
4. Wait 13 seconds until both LEDs are off.
5. To apply the factory settings, separate M from Teach-in within 5 seconds before switching off the supply voltage.
- ✓ The product is reset to the factory settings. Product automatically switches to normal operation mode.

##### UM12-xxxxx1x, UM12-xxxxx5x

1. Switch off the supply voltage.
2. Apply L+ at Teach-in.
3. Switch on the supply voltage.
4. Wait 13 seconds until both LEDs are flashing simultaneously.
5. To apply the factory settings, separate L+ from Teach-in within 5 seconds before switching off the supply voltage.
- ✓ The product is reset to the factory settings. Product automatically switches to normal operation mode.

## 7.5 Activating and deactivating teach-in and synchronization

#### Overview

Valid for devices with IO-Link (UM12-xxxxxBx).

#### Procedure

1. Switch off the supply voltage.
2. Apply M at Teach-in/Synch.
3. Switch on the supply voltage.
4. Wait 3 seconds until both LEDs are flashing simultaneously.
- ✓ Green LED flashes.
- ✓ Teach-in and synchronization are activated: Orange LED lights up.
- ✓ Teach-in and synchronization are deactivated: Orange LED does not light up.
5. To change the setting, apply M at Teach-in/Synch for 1 second.

- ✓ Orange LED changes its status.
- 6. Wait 10 seconds.
- ✓ Green LED no longer flashes.
- ✓ Teach-in and synchronization are activated or deactivated. The product automatically switches to normal operation mode.

### 7.6 IO-Link

Depending on the product type, the product can exchange process data and parameters via IO-Link. To do this, connect the product to a suitable IO-Link Master. A sensor-specific device description file (IODD) is required in the IO-Link Master. The IODD and a supplementary information document are available on the product page.

The product page can be accessed via the **SICK Product ID**: [pid.sick.com/{P/N}/{S/N}](http://pid.sick.com/{P/N}/{S/N})

{P/N} corresponds to the part number of the product, see type label.

{S/N} corresponds to the serial number of the product, see type label (if indicated).

### 7.7 Establishing a connection to SOPAS ET

#### Overview

The SOPAS Engineering Tool (SOPAS ET) software is suitable for parameterization as well as for service and diagnostics purposes.

#### Prerequisites

- Product type with IO-Link
- A computer with the SOPAS ET software installed on it, and a free USB 2.0 compatible port



#### NOTE

The most up-to-date version of the SOPAS ET software can be downloaded from [www.sick.com/SOPAS\\_ET](http://www.sick.com/SOPAS_ET). The respective system requirements for installing SOPAS ET are also specified there.

- 
- SICK SiLink2 Master (available as accessory)
  - Connection cable with M12 male and female connectors, 4-pin (available as accessory)
  - Device description file (SDD)



#### NOTE

The SDD can be installed in SOPAS ET or via the SICK website. Follow the instructions in SOPAS ET.

---

#### Procedure

1. Connect the product to the SiLink2 Master via the male connector or an additional connection cable.
2. Connect the SiLink2 Master to the computer using the supplied USB cable.
3. Switch on and start the computer.
4. To ensure an adequate voltage supply to the product, also connect the enclosed wall plug to the SiLink2 Master.
- ✓ The status LEDs light up green after successful initialization. The product is ready for operation.
5. Install the device description file.
6. Select the product from the device catalog and add it to a project.
- ✓ A connection to the product is established via the communication interface. The connection must be activated for data transmission (**online**).

## 8 Maintenance

### 8.1 Maintenance schedule

During operation, the device is maintenance-free.

Table 6: Maintenance schedule

Maintenance work	Interval	To be carried out by
Check device and connecting cables for damage at regular intervals.	Depends on ambient conditions and climate.	Specialist
Check the screw connections and plug connections.	Depends on the place of use, ambient conditions or operating requirements. Recommended: At least every 6 months.	Specialist

### 8.2 Cleaning



**NOTICE**

**Equipment damage due to improper cleaning.**

Improper cleaning may result in equipment damage.

- Only use recommended cleaning agents and tools.
- Never use sharp objects for cleaning.

### 9 Troubleshooting

#### 9.1 Repair

Repairs on the device may only be performed by qualified and authorized personnel from SICK AG. Interference with or modifications to the device on the part of the customer will invalidate any warranty claims against SICK AG.

#### 9.2 Return

- ▶ Only send in devices after consulting with SICK Service.
- ▶ The device must be sent in the original packaging or an equivalent padded packaging.



##### NOTE

To enable efficient processing and allow us to determine the cause quickly, please include the following when making a return:

- Details of the contact person
  - Description of the application
  - Description of the error that occurred
- 

#### 9.3 Disposal

If a device can no longer be used, dispose of it in an environmentally friendly manner in accordance with the applicable country-specific waste disposal regulations. Do not dispose of the product along with household waste.



##### NOTICE

**Danger to the environment due to improper disposal of the device.**

Disposing of devices improperly may cause damage to the environment.

Therefore, observe the following information:

- Always observe the national regulations on environmental protection.
  - Separate the recyclable materials by type and place them in recycling containers.
-

## 10 Technical data

### 10.1 Mechanics/Electronics

<b>Supply voltage <math>V_s</math></b>	Digital output: DC 10 V ... 30 V <sup>1)</sup> Analog voltage output: DC 15 V ... 30 V <sup>1)</sup> Analog current output: DC 10 V ... 30 V at $R_L \leq 100 \Omega$ , DC 15 V ... 30 V at $R_L > 100 \Omega$ <sup>1)</sup>
<b>Power consumption</b>	Products with digital output: <ul style="list-style-type: none"> <li>• UM12-11722x1: <math>\leq 0.75 \text{ W}</math> <sup>2)</sup></li> <li>• UM12-119 22x1: <math>\leq 1.05 \text{ W}</math> <sup>2)</sup></li> </ul> Products with analog output: <ul style="list-style-type: none"> <li>• UM12-11722x1: <math>\leq 0.9 \text{ W}</math> <sup>2)</sup></li> <li>• UM12-11922x1: <math>\leq 1.2 \text{ W}</math> <sup>2)</sup></li> </ul>
<b>Power-up time</b>	< 300 ms
<b>Design</b>	Cylindrical
<b>Housing material</b>	Metal (nickel plated brass, PBT) Ultrasonic converter: Polyurethane foam, epoxy resin with glass content
<b>Threaded size</b>	M12 x 1
<b>Connection type</b>	Male connector, M12, 4-pin
<b>Display</b>	2 x LED
<b>Weight</b>	15 g
<b>Sending axis</b>	Straight
<b>Dimensions (W x H x D)</b>	Digital output: 12 mm x 12 mm x 55.1 mm Analog output: 12 mm x 12 mm x 60.1 mm
<b>Enclosure rating</b>	IP65 / IP67 (EN 60529)
<b>Protection class</b>	III
<b>Maximum tightening torque for fixing nuts</b>	1 Nm

<sup>1)</sup> Limit values, reverse-polarity protected Operation in short-circuit protected network: max. 8 A, class 2.

<sup>2)</sup> Without load.

### 10.2 Performance

<b>Operating range</b>	UM12-11722x1: 20 mm ... 150 mm UM12-11922x1: 40 mm ... 240 mm
<b>Limiting range</b>	UM12-11722x1: 250 mm UM12-11922x1: 350 mm
<b>Measuring object</b>	Natural objects
<b>Resolution</b>	$\geq 0.069 \text{ mm}$
<b>Repeatability</b>	$\pm 0.15\%$ <sup>1)</sup>
<b>Accuracy</b>	$\pm 1\%$ <sup>2)</sup>
<b>Temperature compensation</b>	Internal temperature compensation
<b>Response time</b>	UM12-11722x1: 24 ms <sup>3)</sup> UM12-11922x1: 30 ms <sup>3)</sup>
<b>Switching frequency <sup>4)</sup></b>	UM12-11722x1: 30 Hz UM12-11922x1: 25 Hz

<b>Output time</b>	UM12-11722x1: 8 ms UM12-11922x1: 10 ms
<b>Ultrasonic frequency (typical)</b>	UM12-11722x1: 380 kHz UM12-11922x1: 500 kHz
<b>Additional function <sup>5)</sup></b>	<ul style="list-style-type: none"> <li>Configurable switching point modes: Single Point Mode, Window Mode (switching window), Window Mode <math>\pm 8\%</math> (teach-in background)</li> <li>Teachable digital output</li> <li>Invertible digital output</li> <li>Reset to factory settings</li> </ul>

- 1) Relative to the current measured value, minimum value  $\geq$  resolution.
- 2) Relative to the current measured value.
- 3) Products with analog output: Subsequent smoothing of the analog output may increase the response time by up to 200% in some applications.
- 4) Valid for products with digital output.
- 5) Functions may vary depending on the sensor variant.

### 10.3 Interfaces

#### Products with digital output

<b>IO-Link</b>	UM12-11x22B1: IO-Link V1.1 Function: Process data, configuration, diagnostics, data storage
<b>digital output</b>	UM12-11x2211: 1 PNP <sup>1)</sup> , maximum output current $I_A \leq 200$ mA UM12-11x2251: 1 NPN <sup>2)</sup> , maximum output current $I_A \leq 200$ mA UM12-11x22B1: 1 push-pull: PNP/NPN <sup>3)</sup> , maximum output current $I_A \leq 100$ mA
<b>Hysteresis</b>	UM12-11722x1: 2 mm UM12-11722x1: 3 mm

- 1) PNP: HIGH =  $U_V - (< 2 V)$  / LOW = 0 V.
- 2) NPN: HIGH  $\leq 2 V$  / LOW =  $U_V$ .
- 3) Push-pull: PNP/NPN: HIGH =  $U_V - (< 3 V)$ /LOW =  $< 3 V$ .

#### Products with analog output

<b>Analog output</b>	4 mA ... 20 mA: $R_L \leq 500 \Omega$ <sup>1)</sup> 0 V ... 10 V: $R_L \geq 100 k\Omega$
<b>Resolution</b>	12 bit

- 1) At 4 mA ... 20 mA and  $U_V \leq 20 V$  max. load  $\leq 100 \Omega$ .

### 10.4 Ambient data

<b>Ambient operating temperature</b>	-25 °C ... +70 °C
<b>Storage temperature</b>	-40 °C ... +85 °C

### 10.5 Temperature compensation

The internal temperature compensation reaches the optimum operating point after 1 minute of operation. Temperature compensation is adjusted at the factory to standard mounting conditions with an aluminum mounting bracket and mounting nuts.

Temperature compensation is automatically adjusted to the individual installation situation under the following conditions.

**Conditions of automatic adjustment of temperature compensation**

- The product is in a cold state.
- Digital output: The digital output is deactivated for approx. 30 minutes.
- Analog output: The analog output delivers a constant value of 11 mA ... 13 mA or 4.4 V ... 5.6 V for approx. 30 minutes.

If the measured value changes in the 30 minutes, the adjustment is canceled. The default parameters or the last adjusted parameters are retained. Automatic adjustment is suitable for installation situations that deviate greatly from standard installation conditions or where high measurement accuracy is required. One example is thermally insulated mounting.

**10.6 Detection ranges**

**UM12-117x**

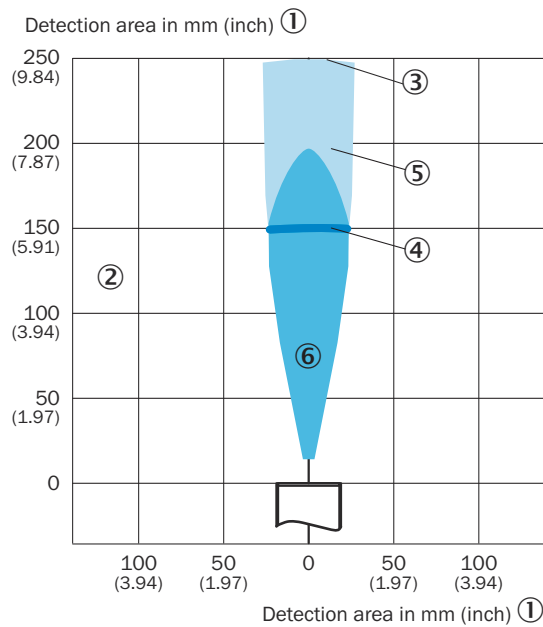

- ① Detection range in mm (inch)
- ② Detection range dependent on reflection properties, size, and alignment of the object
- ③ Limiting range
- ④ Operating range
- ⑤ Example object: aligned plate 500 mm x 500 mm
- ⑥ Example object: Cylindrical bar with diameter of 10 mm

**UM12-119x**

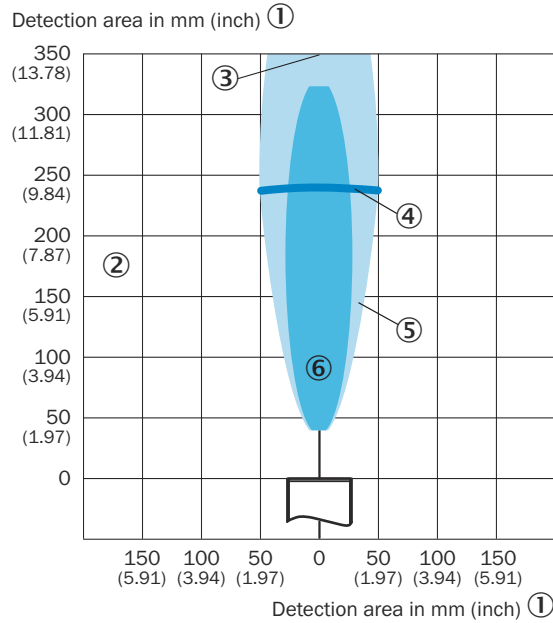

- ① Detection range in mm (inch)
- ② Detection range dependent on reflection properties, size, and alignment of the object
- ③ Limiting range
- ④ Operating range
- ⑤ Example object: aligned plate 500 mm x 500 mm
- ⑥ Example object: Cylindrical bar with diameter of 10 mm

**10.7 Dimensional drawing**

**UM12-xxxxx1x, UM12-xxxxx5x, UM12-xxxxxBx**

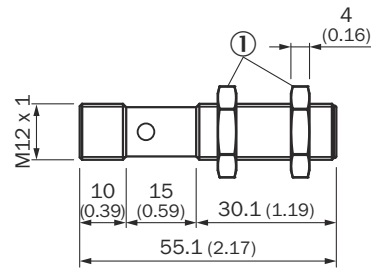

Figure 12: structure and device dimensions, unit: mm (inch), decimal separator: period

- ① Fixing nuts, width 17 mm

UM12-xxxxx6x, UM12-xxxxx7x

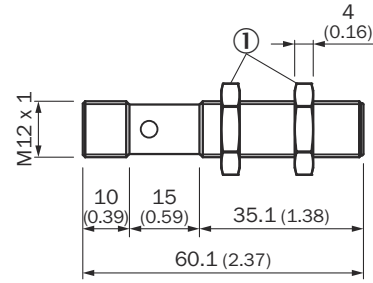

Figure 13: structure and device dimensions, unit: mm (inch), decimal separator: period

- ① Fixing nuts, width 17 mm

### 11 Accessories

---

**NOTE**

On the product page you will find accessories and, if applicable, related installation information for your product.

The product page can be accessed via the **SICK Product ID: [pid.sick.com/{P/N}/{S/N}](https://pid.sick.com/{P/N}/{S/N})**

**{P/N}** corresponds to the part number of the product, see type label.

**{S/N}** corresponds to the serial number of the product, see type label (if indicated).

---

## 12 Annex

### 12.1 Declarations of conformity and certificates

You can download declarations of conformity and certificates via the product page.

The product page can be accessed via the **SICK Product ID: [pid.sick.com/{P/N}/{S/N}](http://pid.sick.com/{P/N}/{S/N})**

**{P/N}** corresponds to the part number of the product, see type label.

**{S/N}** corresponds to the serial number of the product, see type label (if indicated).

### 12.2 Licenses

SICK uses open source software which is published by the rights holders under a free license. Among others, the following license types are used: GNU General Public License (GPL version 2, GPL version 3), GNU Lesser General Public License (LGPL), MIT license, zlib license and licenses derived from the BSD license.

This program is provided for general use without warranty of any kind. This warranty disclaimer also extends to the implicit assurance of marketability or suitability of the program for a particular purpose.

More details can be found in the GNU General Public License.

For license texts see [www.sick.com/licensetexts](http://www.sick.com/licensetexts).

Printed copies of the license texts are also available on request.

**Australia**

Phone +61 (3) 9457 0600  
1800 33 48 02 – tollfree  
E-Mail sales@sick.com.au

**Austria**

Phone +43 (0) 2236 62288-0  
E-Mail office@sick.at

**Belgium/Luxembourg**

Phone +32 (0) 2 466 55 66  
E-Mail info@sick.be

**Brazil**

Phone +55 11 3215-4900  
E-Mail comercial@sick.com.br

**Canada**

Phone +1 905.771.1444  
E-Mail cs.canada@sick.com

**Czech Republic**

Phone +420 234 719 500  
E-Mail sick@sick.cz

**Chile**

Phone +56 (2) 2274 7430  
E-Mail chile@sick.com

**China**

Phone +86 20 2882 3600  
E-Mail info.china@sick.net.cn

**Denmark**

Phone +45 45 82 64 00  
E-Mail sick@sick.dk

**Finland**

Phone +358-9-25 15 800  
E-Mail sick@sick.fi

**France**

Phone +33 1 64 62 35 00  
E-Mail info@sick.fr

**Germany**

Phone +49 (0) 2 11 53 010  
E-Mail info@sick.de

**Greece**

Phone +30 210 6825100  
E-Mail office@sick.com.gr

**Hong Kong**

Phone +852 2153 6300  
E-Mail ghk@sick.com.hk

**Hungary**

Phone +36 1 371 2680  
E-Mail ertebsites@sick.hu

**India**

Phone +91-22-6119 8900  
E-Mail info@sick-india.com

**Israel**

Phone +972 97110 11  
E-Mail info@sick-sensors.com

**Italy**

Phone +39 02 27 43 41  
E-Mail info@sick.it

**Japan**

Phone +81 3 5309 2112  
E-Mail support@sick.jp

**Malaysia**

Phone +603-8080 7425  
E-Mail enquiry.my@sick.com

**Mexico**

Phone +52 (472) 748 9451  
E-Mail mexico@sick.com

**Netherlands**

Phone +31 (0) 30 204 40 00  
E-Mail info@sick.nl

**New Zealand**

Phone +64 9 415 0459  
0800 222 278 – tollfree  
E-Mail sales@sick.co.nz

**Norway**

Phone +47 67 81 50 00  
E-Mail sick@sick.no

**Poland**

Phone +48 22 539 41 00  
E-Mail info@sick.pl

**Romania**

Phone +40 356-17 11 20  
E-Mail office@sick.ro

**Singapore**

Phone +65 6744 3732  
E-Mail sales.gsg@sick.com

**Slovakia**

Phone +421 482 901 201  
E-Mail mail@sick-sk.sk

**Slovenia**

Phone +386 591 78849  
E-Mail office@sick.si

**South Africa**

Phone +27 10 060 0550  
E-Mail info@sickautomation.co.za

**South Korea**

Phone +82 2 786 6321/4  
E-Mail infokorea@sick.com

**Spain**

Phone +34 93 480 31 00  
E-Mail info@sick.es

**Sweden**

Phone +46 10 110 10 00  
E-Mail info@sick.se

**Switzerland**

Phone +41 41 619 29 39  
E-Mail contact@sick.ch

**Taiwan**

Phone +886-2-2375-6288  
E-Mail sales@sick.com.tw

**Thailand**

Phone +66 2 645 0009  
E-Mail marcom.th@sick.com

**Turkey**

Phone +90 (216) 528 50 00  
E-Mail info@sick.com.tr

**United Arab Emirates**

Phone +971 (0) 4 88 65 878  
E-Mail contact@sick.ae

**United Kingdom**

Phone +44 (0)17278 31121  
E-Mail info@sick.co.uk

**USA**

Phone +1 800.325.7425  
E-Mail info@sick.com

**Vietnam**

Phone +65 6744 3732  
E-Mail sales.gsg@sick.com

Detailed addresses and further locations at [www.sick.com](http://www.sick.com)