



SBO-02F12-SM1

**SICK**  
Sensor Intelligence.



Illustration may differ

## Ordering information

Type	Part no.
SBO-02F12-SM1	6053172

Other models and accessories → [www.sick.com/](http://www.sick.com/)

## Detailed technical data

### Technical specifications

<b>Accessory group</b>	Distributors
<b>Accessory family</b>	T-junctions
<b>Connection type head A</b>	Female connector, M12, 5-pin, A-coded
<b>Connection type head B</b>	Female connector, M12, 8-pin, A-coded
<b>Connector color</b>	Black
<b>Reference voltage</b>	≤ 30 V DC
<b>Current loading</b>	4 A
<b>Note</b>	Male connector M12, 8-pin, to 1 x female connector M12, 8-pin, to 1 x female connector M12, 5-pin For connecting of a PLC
<b>Enclosure rating</b>	IP67 <sup>1)</sup>
<b>Ambient operating temperature</b>	Head -30 °C ... +90 °C

<sup>1)</sup> Only in fully locked position with its plugs.

### Classifications

<b>eCl@ss 5.0</b>	27279201
<b>eCl@ss 5.1.4</b>	27279201
<b>eCl@ss 6.0</b>	27279201
<b>eCl@ss 6.2</b>	27279201
<b>eCl@ss 7.0</b>	27279201
<b>eCl@ss 8.0</b>	27279201
<b>eCl@ss 8.1</b>	27279201
<b>eCl@ss 9.0</b>	27440108
<b>eCl@ss 10.0</b>	27440108
<b>eCl@ss 11.0</b>	27440108
<b>eCl@ss 12.0</b>	27440108
<b>ETIM 5.0</b>	EC002585
<b>ETIM 6.0</b>	EC002585
<b>ETIM 7.0</b>	EC002585

ETIM 8.0	EC002585
UNSPSC 16.0901	31163032

Dimensional drawing (Dimensions in mm (inch))

SBO-02F12-SM

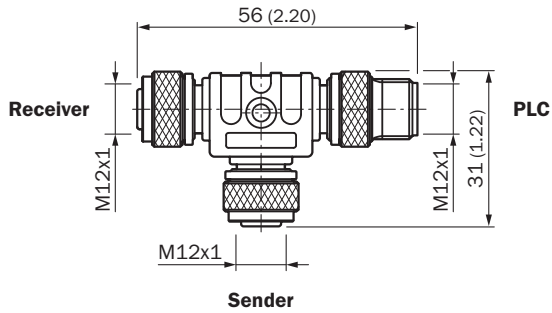

Connection type

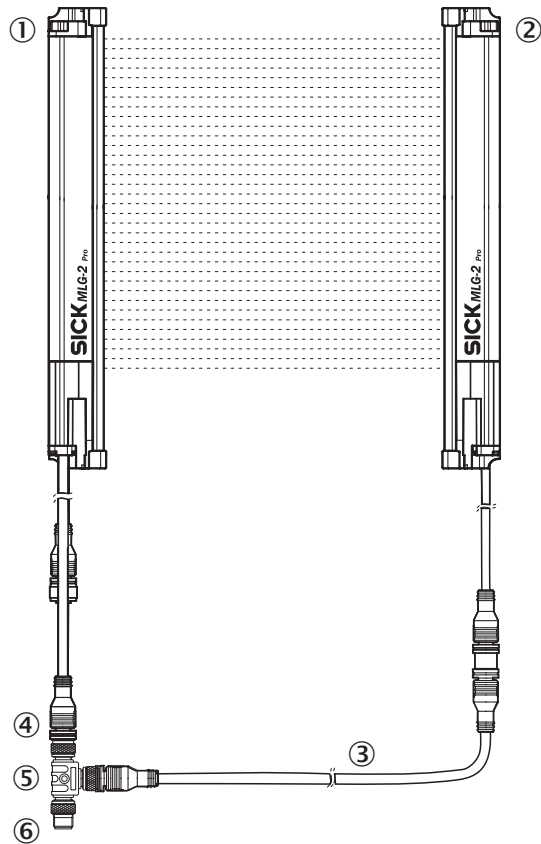

- ① MLG-2 receiver
- ② MLG-2 sender
- ③ Connection cable
- ④ MLG-2 connection
- ⑤ T-piece
- ⑥ Connection

Anschlussschema

T-piece

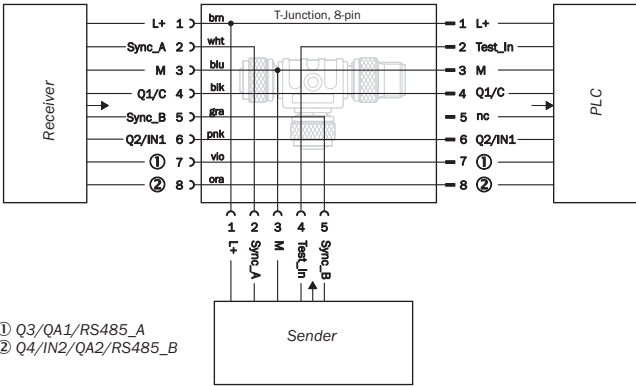

## SICK AT A GLANCE

SICK is one of the leading manufacturers of intelligent sensors and sensor solutions for industrial applications. A unique range of products and services creates the perfect basis for controlling processes securely and efficiently, protecting individuals from accidents and preventing damage to the environment.

We have extensive experience in a wide range of industries and understand their processes and requirements. With intelligent sensors, we can deliver exactly what our customers need. In application centers in Europe, Asia and North America, system solutions are tested and optimized in accordance with customer specifications. All this makes us a reliable supplier and development partner.

Comprehensive services complete our offering: SICK LifeTime Services provide support throughout the machine life cycle and ensure safety and productivity.

For us, that is “Sensor Intelligence.”

## WORLDWIDE PRESENCE:

Contacts and other locations –[www.sick.com](http://www.sick.com)