



YM08U13-0002K1823A

SICK
Sensor Intelligence.



Ordering information

Type	Part no.
YM08U13-0002K1823A	2122277

Please consider the operational voltage of the connector. For sensors with an integrated cable and flying leads the operational voltage of the connector can be lower than the operational voltage of the sensor.

Other models and accessories → www.sick.com/

Detailed technical data

Technical specifications

Accessory group	Plug connectors and cables
Accessory family	Field-attachable connectors
Connection type head A	Male connector, M8, 3-pin, straight, A-coded
Connection type	IDC quick connection
Locking plug connector	Screw connection
Connector material	PA
Connector color	Black
Locking nut material	Nickel-plated brass
Seal material	NBR
Tightening torque	0.2 Nm
Width across flats	9
Cable diameter	Ø 1.9 mm
Permitted cable diameter	2.5 mm ... 5.1 mm
Permitted cross-section	0.08 mm ² ... 0.25 mm ²
Reference voltage	≤ 48 V AC, ≤ 60 V DC
Current loading	≤ 4 A
Signal type	Sensor/actuator cable
Enclosure rating	IP67
Ambient operating temperature	Head -25 °C ... +80 °C
Contamination rating	3
Insulation resistance	100 MΩ
Overvoltage category	II

Instruction for installation

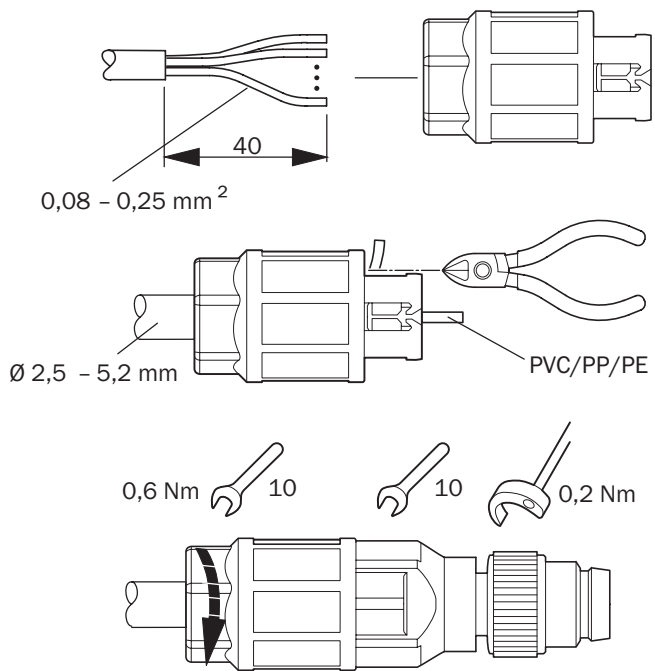

SICK AT A GLANCE

SICK is one of the leading manufacturers of intelligent sensors and sensor solutions for industrial applications. A unique range of products and services creates the perfect basis for controlling processes securely and efficiently, protecting individuals from accidents and preventing damage to the environment.

We have extensive experience in a wide range of industries and understand their processes and requirements. With intelligent sensors, we can deliver exactly what our customers need. In application centers in Europe, Asia and North America, system solutions are tested and optimized in accordance with customer specifications. All this makes us a reliable supplier and development partner.

Comprehensive services complete our offering: SICK LifeTime Services provide support throughout the machine life cycle and ensure safety and productivity.

For us, that is “Sensor Intelligence.”

WORLDWIDE PRESENCE:

Contacts and other locations –www.sick.com