



MLP1-SMUCOAC

MLP1

SAFETY LOCKING DEVICES

SICK
Sensor Intelligence.



Ordering information

Type	Part no.
MLP1-SMUCOAC	1117390

Consists of sensor (1117630) and actuator (1078199)

Other models and accessories → www.sick.com/MLP1



Detailed technical data

Features

Sensor principle	RFID
Locking principle	Power to lock
Coding	Uniquely coded
Locking force F_{max}	550 N (GS-ET-19)
Locking force F_{Zh}	500 N (GS-ET-19)
Retaining force	25 N
Offset tolerance	≤ 5 mm
Safe switch off distance S_{ar}	35 mm
For process protection only	✓

Safety-related parameters

Safety integrity level	SIL3 (IEC 61508)
Category	Category 4 (EN ISO 13849)
Performance level	PL e (EN ISO 13849) ¹⁾
PFH_D (mean probability of a dangerous failure per hour)	$15 * 10^{-9}$ ²⁾
T_M (mission time)	20 years (EN ISO 13849)
Type	Type 4 (EN ISO 14119)
Actuator coding level	High coding level (EN ISO 14119)
Safe state in the event of a fault	At least one safety-related semiconductor output (OSSD) is in the OFF state.

¹⁾ In a safe series connection, the performance level for the safe series connection as a whole depends on the number and type of devices in the safe series connection. PL e is only possible in safe series connections with a maximum of 6 devices.

²⁾ At 40 °C and 1000 m above sea level.

Functions

Switching behavior of the OSSDs	Actuator monitoring
Safe series connection	Direct (without diagnostics)

Interfaces

Connection type	Cable with plug M12, 5-pin Cable with female connector, M12, 5-pin
Length of cable	150 mm
Long connecting cable	≤ 140 m
Cable diameter	5.5 mm
Conductor cross section	0.12 mm ²
Bend radius (with fixed installation)	> 8 x cable diameter
Bend radius (with moving cable)	> 12 x cable diameter
Cable material	PVC
Conductor material	Copper
Coupling nut material	Zinc die-cast, nickel-plated
Status display	✓

Electrical data

Protection class	III (IEC 61140)
Contamination rating	3 (EN 60947-1)
Classification according to cULus	Class 2
Usage category	DC-13 (IEC 60947-5-1)
Rated insulation voltage U_i	32 V
Rated impulse withstand voltage U_{imp}	1,500 V
Supply voltage U_V when an individual safety switch is connected	
Sensor	24 V DC (19.2 V DC ... 28.8 V DC)
Magnet	24 V DC (19.2 V DC ... 28.8 V DC)
Supply voltage U_V when a cascade is connected	
Sensor	24 V DC (22.8 V DC ... 28.8 V DC)
Magnet	24 V DC (21.6 V DC ... 28.8 V DC)
Power consumption	
Locking active	350 mA
Locking deactivated	50 mA
Switching frequency	≤ 0.5 Hz
Type of output	Self-monitoring semiconductor outputs (OSSDs)
Output current (OSSDs)	≤ 100 mA
Diagnostic output	≤ 25 mA, short-circuit protected
Cable capacitance	400 nF (for OUT A and OUT B)
Response time	50 ms ¹⁾
Release time	100 ms ¹⁾
Risk time	100 ms ¹⁾
Switch-on time	2.5 s
Locking principle	Power to lock

¹⁾ In a cascade, the value is multiplied by the number of safety switches in the cascade.

Mechanical data

Weight	Switches (spare parts)	510 g
	Actuator	210 g
Material	Sensor housing	Anodized aluminum
	Actuator housing	Fiber-glass-reinforced PVC
	Anchor plate	Nickel-plated steel
Dimensions (W x H x D)	Switches (spare parts)	120 mm x 60 mm x 38.5 mm
	Actuator	120 mm x 60 mm x 20.5 mm
Offset tolerance	Vertical	≤ 5 mm
	Horizontal	≤ 5 mm
	Aperture angle	≤ 3°

Ambient data

Enclosure rating	IP67 (EN 60529)
Ambient operating temperature	-20 °C ... +55 °C
Storage temperature	-25 °C ... +70 °C
Relative humidity	50 %, at 70 °C (IEC 60947-5-2)
Vibration resistance	10 Hz ... 55 Hz, 1 mm (IEC 60068-2-6)
Shock resistance	30 g, 11 ms (EN 60068-2-27)
EMC	EN IEC 61326-3-1 EN IEC 60947-5-2 EN IEC 60947-5-3

Classifications

eCl@ss 5.0	27272603
eCl@ss 5.1.4	27272603
eCl@ss 6.0	27272603
eCl@ss 6.2	27272603
eCl@ss 7.0	27272603
eCl@ss 8.0	27272603
eCl@ss 8.1	27272603
eCl@ss 9.0	27272603
eCl@ss 10.0	27272603
eCl@ss 11.0	27272603
eCl@ss 12.0	27272603
ETIM 5.0	EC002593
ETIM 6.0	EC002593
ETIM 7.0	EC002593
ETIM 8.0	EC002593
UNSPSC 16.0901	39122205

Dimensional drawing (Dimensions in mm (inch))

Sensor with M12 male connector and M12 socket

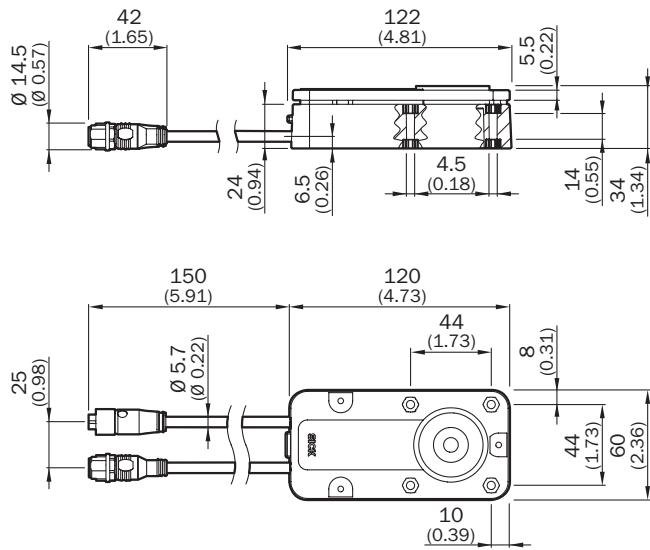

Actuator

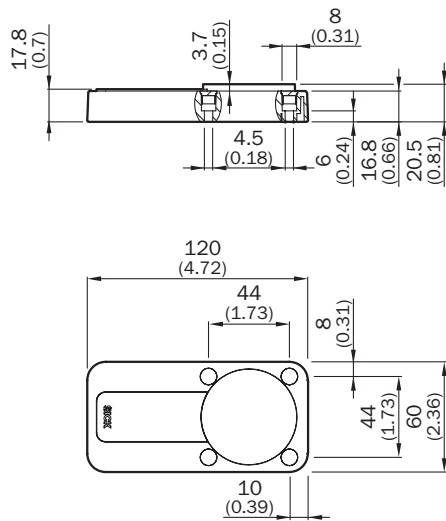

Recess for flush mounting

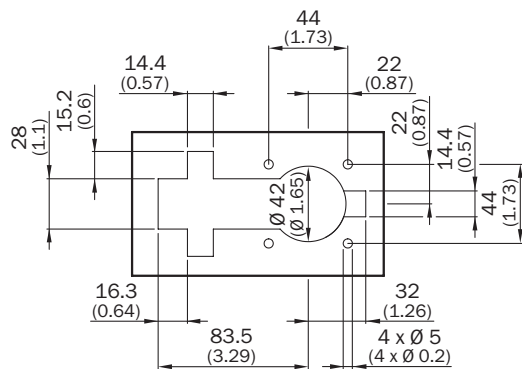

Series connection

Connecting an additional voltage supply

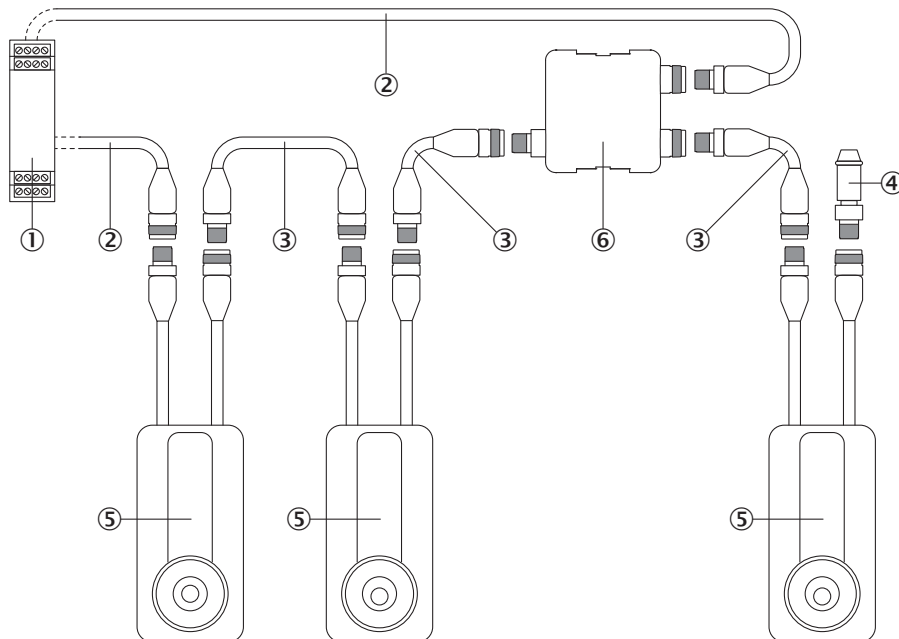

- ① Safe evaluation unit
- ② Connecting cable with M12 female connector, 5-pin and flying leads (e.g., YF2A15-xxxVB5XLEAX)
- ③ Connection cable with 5-pin, M12 male connector and 5-pin, M12 female connector (e.g., YF2A15-xxxUB5M2A15)
- ④ End plug
- ⑤ MLP1 safety switch (2 × M12, 5-pin)
- ⑥ Nodes for voltage supply

Connecting directly connected safety switches

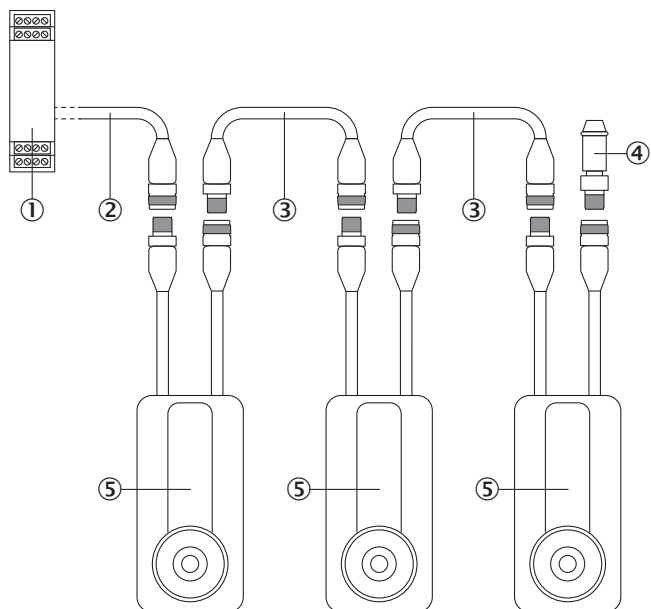

- ① Safe evaluation unit
- ② Connecting cable with M12 female connector, 5-pin and flying leads (e.g., YF2A15-xxxVB5XLEAX)
- ③ Connection cable with 5-pin, M12 male connector and 5-pin, M12 female connector (e.g., YF2A15-xxxUB5M2A15)
- ④ End plug
- ⑤ MLP1 safety switch (2 × M12, 5-pin)

Combining connection methods as desired

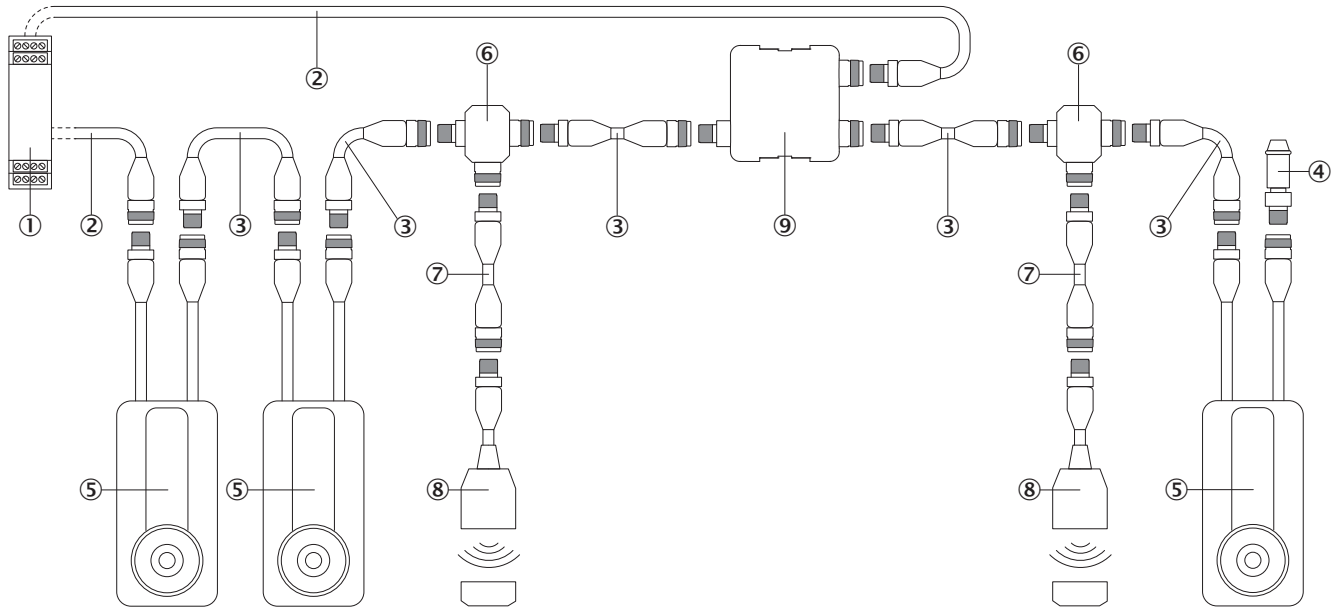

- ① Safe evaluation unit
- ② Connecting cable with M12 female connector, 5-pin and flying leads (e.g., YF2A15-xxxVB5XLEAX)
- ③ Connection cable with 5-pin, M12 male connector and 5-pin, M12 female connector (e.g., YF2A15-xxxUB5M2A15)
- ④ End plug
- ⑤ MLP1 safety switch
- ⑥ T-piece
- ⑦ Connection cable with 8-pin, M12 male connector and 8-pin, M12 female connector (e.g., YF2A18-xxxUA5M2A18)
- ⑧ Safety switch, M12, 8-pin
- ⑨ Nodes for voltage supply

Pin assignment

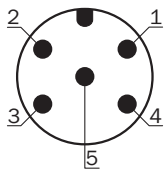

Pin	Designation	Description
1	In 24 V DC	Safety switch voltage supply
2	OSSD 1	OSSD 1 output
3	0 V	0 V DC voltage supply
4	OSSD 2	OSSD 2 output
5	Magnet	Magnet control 24 V DC input

For details see operating instructions

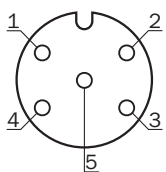

Pin	Designation	Description
1	Out 24 V DC	Safety switch voltage supply
2	In 1	Input OSSD 1
3	0 V	0 V DC voltage supply
4	In 2	Input OSSD 2
5	Magnet	Magnet control 24 V DC output

For details see operating instructions

SICK AT A GLANCE

SICK is one of the leading manufacturers of intelligent sensors and sensor solutions for industrial applications. A unique range of products and services creates the perfect basis for controlling processes securely and efficiently, protecting individuals from accidents and preventing damage to the environment.

We have extensive experience in a wide range of industries and understand their processes and requirements. With intelligent sensors, we can deliver exactly what our customers need. In application centers in Europe, Asia and North America, system solutions are tested and optimized in accordance with customer specifications. All this makes us a reliable supplier and development partner.

Comprehensive services complete our offering: SICK LifeTime Services provide support throughout the machine life cycle and ensure safety and productivity.

For us, that is “Sensor Intelligence.”

WORLDWIDE PRESENCE:

Contacts and other locations –www.sick.com