



PFG05-A1KM0160

EcoLine

WIRE DRAW ENCODERS

SICK
Sensor Intelligence.



Illustration may differ



Ordering information

Type	Part no.
PFG05-A1KM0160	1060972

Other models and accessories → www.sick.com/EcoLine

Detailed technical data

Performance

Measurement range	0 m ... 1.25 m
Reproducibility	≤ 0.2 mm ^{1) 2)}
Linearity	≤ ± 2 mm ^{1) 3)}
Hysteresis	≤ 0.4 mm ^{1) 4)}
Resolution (wire draw + encoder)	0.06 mm ^{5) 6)}

¹⁾ Value applies to wire draw mechanism.

²⁾ Reproducibility, repetition accuracy, or even repeatability is defined as the maximum scatter from consecutive positioning operations from a single direction to a point, carried out under identical conditions.

³⁾ The accuracy of wire draw encoders is primarily described by the linearity. This indicates the maximum deviation for the measurement of a defined measuring path. In contrast to repeatability, this relates to the measuring range covered and not to a positioning point.

⁴⁾ The hysteresis is defined as the maximum scatter from consecutive positioning operations from different directions to a point, carried out under identical conditions.

⁵⁾ The values shown have been rounded.

⁶⁾ Example calculation based on the PFG08 with HTL Push Pull: 230 mm (wire draw length per revolution - see Mechanical data): 16,384 (pulses per revolution) = 0.014 mm (resolution of wire draw + encoder combination).

Interfaces

Encoder	Incremental encoders
Electrical interface	TTL
Connection type	Cable, 8-wire, universal, 1.5 m

Electrical data

Maximum output frequency	≤ 300 kHz
Reference signal, position	90°, electric, logically gated with A and B
Reference signal, number	Electric, logically gated with A and B
Maximum load current	≤ 30 mA

¹⁾ Valid positional data can be read once this time has elapsed.

²⁾ This product is a standard product and does not constitute a safety component as defined in the Machinery Directive. Calculation based on nominal load of components, average ambient temperature 40 °C, frequency of use 8760 h/a. All electronic failures are considered hazardous. For more information, see document no. 8015532.

³⁾ The value applies to the mounted encoder.

Initialization time	≤ 3 ms ^{1) 1)}
Supply voltage	4.5 V ... 5.5 V
Power consumption	0.5 W
MTTFd: mean time to dangerous failure	600 years ^{2) 3)}

¹⁾ Valid positional data can be read once this time has elapsed.

²⁾ This product is a standard product and does not constitute a safety component as defined in the Machinery Directive. Calculation based on nominal load of components, average ambient temperature 40 °C, frequency of use 8760 h/a. All electronic failures are considered hazardous. For more information, see document no. 8015532.

³⁾ The value applies to the mounted encoder.

Mechanical data

Weight (including encoder)	230 g
Weight (mechanics)	80 g
Measuring wire material	Highly flexible stranded steel 1.4401 stainless steel V4A/PA sheathed
Weight (measuring wire)	0.58 g/m
Housing material, wire draw mechanism	Plastic, Noryl
Length of wire pulled out per revolution	150 mm
Spring return force	1 N ... 1.4 N ¹⁾
Life of wire draw mechanism	Typ. 1 million cycles ^{2) 3)}
Actual wire draw length	1.45 m
Measuring wire diameter	0.45 mm
Wire acceleration	10 m/s ²
Operating speed	4 m/s
Mounted encoder	DBS36 Core
Pulses per revolution	2,500
Part number encoder	1064245
Mounted mechanic	MRA-G055-101D4
Part number mechanic	5324019

¹⁾ These values were measured at an ambient temperature of 25 °C. There may be variations at other temperatures.

²⁾ A cycle consists of the wire being pulled out and drawn in.

³⁾ The service life depends on the type of load. This is influenced by environmental conditions, the installation location, the measuring range in use, the traversing speed, and acceleration.

Ambient data

EMC	According to EN 61000-6-2 and EN 61000-6-3 (class A)
Enclosure rating encoder	IP65
Enclosure rating mechanic	IP50
Resistance to shocks	100 g, 6 ms (according to EN 60068-2-27)
Frequency range of resistance to vibrations	20 g, 10 Hz ... 2,000 Hz (according to EN 60068-2-6)
Working temperature range (encoder)	-30 °C ... +70 °C
Working temperature range (mechanics)	-30 °C ... +70 °C
Working temperature range (combination)	Defined by the higher minimum and lower maximum value of the operating temperature of the encoder and the mechanism
Relative humidity/condensation	90 % (condensation of the optical scanning not permitted)

Classifications

ECl@ss 5.0	27270590
ECl@ss 5.1.4	27270590
ECl@ss 6.0	27270590
ECl@ss 6.2	27270590
ECl@ss 7.0	27270590
ECl@ss 8.0	27270590
ECl@ss 8.1	27270590
ECl@ss 9.0	27270590
ETIM 5.0	EC001486
ETIM 6.0	EC001486
UNSPSC 16.0901	41112113

Dimensional drawing (Dimensions in mm (inch))

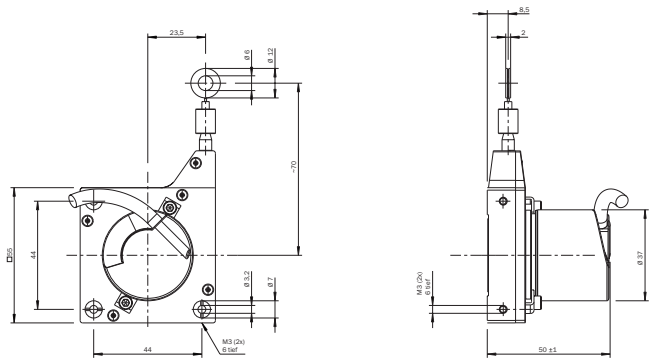

PIN assignment

8-core cable

View of M12 device connector on cable

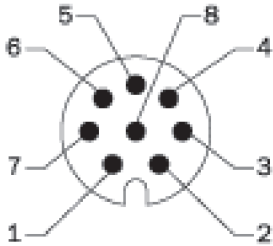

View of M23 device connector on cable

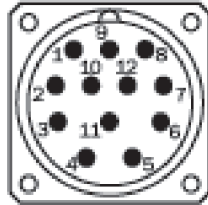



Wire color	Pin 8-pole for M12	Pin 12-pole for M23	Signal HTL/ OC 3-channel	Signal TTL/ HTL 6-channel	Explanation
brown	1	6	Not connected	A-	Signal wire
white	2	5	A	A	Signal wire
black	3	1	Not connected	B-	Signal wire
pink	4	8	B	B	Signal wire
Yellow	5	4	Not connected	Z-	Signal wire
purple	6	3	Z	Z	Signal wire
blue	7	10	GND	GND	Ground connection of the encoder
Red	8	12	+Us	+Us	Supply voltage
-	-	9	Not connected	Not connected	Not connected
-	-	2	Not connected	Not connected	Not connected
-	-	11	Not connected	Not connected	Not connected
-	-	7	Not connected	Not connected	Not connected
Shield	Shield	Shield	Shield	Shield	Shield (connected with housing on the encoder side)

Recommended accessories

Other models and accessories → www.sick.com/EcoLine

	Brief description	Type	Part no.
Plug connectors and cables			
	Head A: cable Head B: open cable ends Cable: SSI, PUR, halogen-free, shielded	LTG-2308-MWENC	6027529
		LTG-2612-MW	6028516
	Head A: female connector, M23, 12-pin, straight Head B: male connector, D-Sub, 9-pin, straight Cable: Incremental, shielded, 0.5 m	DSL-3D08-G0M5AC3	2046580

	Brief description	Type	Part no.
Programming and configuration tools			
	Programming unit display for programmable SICK DFS60, DFV60, AFS/AFM60, AHS/AHM36 encoders, and wire draw encoder with DFS60, AFS/AFM60 and AHS/AHM36. Compact dimensions, low weight, and intuitive operation.	PGT-10-Pro	1072254
Wire draw mechanism			
	EcoLine wire draw mechanism for servo flange with 6 mm shaft, measuring range 0 m ... 1.25 m	MRA-G055-101D4	5324019

SICK AT A GLANCE

SICK is one of the leading manufacturers of intelligent sensors and sensor solutions for industrial applications. A unique range of products and services creates the perfect basis for controlling processes securely and efficiently, protecting individuals from accidents and preventing damage to the environment.

We have extensive experience in a wide range of industries and understand their processes and requirements. With intelligent sensors, we can deliver exactly what our customers need. In application centers in Europe, Asia and North America, system solutions are tested and optimized in accordance with customer specifications. All this makes us a reliable supplier and development partner.

Comprehensive services complete our offering: SICK LifeTime Services provide support throughout the machine life cycle and ensure safety and productivity.

For us, that is “Sensor Intelligence.”

WORLDWIDE PRESENCE:

Contacts and other locations –www.sick.com